



11.-13. Juli 2024

# RALLY GUIDE 2024

## RALLYE WEIZ



### HISTORIC INFOS & MAPS



## Dear EHRC teams participating in the Rally Weiz

With this document we want to give you an overview of the most important information, route maps, etc. for the Rally Weiz. The status of the document and the information contained therein was created to the best of our knowledge, based on the current status. It is possible that there may be minor changes to details before the event. In general, we refer to the „Supplementary Regulations“ for the event as well as to the applicable general regulations of the FIA and/or AMF.

**This document is for informational purposes only, to help teams to prepare for the rally.** In particular, we refer to the additional remote service zones, which are intended exclusively for participants of the FIA EHRC.

**We wish all participants a safe journey to the rally and a successful participation at the Rally Weiz!**



## Sehr geehrte teilnehmende Teams an der Rallye Weiz!

Mit dieser Unterlage wollen wir Euch einen Überblick über die wichtigsten Informationen, Streckenpläne usw. zur Rallye Weiz geben. Der Stand der Unterlage bzw. der darin enthaltenen Informationen wurde nach bestem Wissen, basierend auf dem heute aktuellen Status erstellt. Es ist möglich, dass es bis zur Veranstaltung noch zu kleineren Detailänderungen kommen kann. Generell verweisen wir auf die „Supplementary Regulations“ zur Veranstaltung sowie auf die jeweils gültige Rahmenausschreibung der FIA bzw. AMF..

**Diese Unterlage hat ausschließlich einen informativen Charakter, um den Teams die Vorbereitung auf die Rallye zu erleichtern.** Insbesondere verweisen wir auf die zusätzlichen Remote Service Zonen, die ausschließlich für die Teilnehmer der FIA EHRC vorgesehen sind.

**Wir wünschen allen Teilnehmern eine gute Anreise und eine erfolgreiche Teilnahme an der Rallye Weiz!**



## 2.3 ORGANISER'S NAME / ADDRESS AND CONTACT DETAILS

Name: RALLYE CLUB STEIERMARK	Contact details for FIA EHRC Teams
Address: Am Straßegg 16	Mrs. Claudia Bidlas
A-8614 Breitenau a.H.	Phone: +43 676 401 10 72
Phone: +43 664 224 07 88	E-mail: <a href="mailto:office@festum.at">office@festum.at</a>
E-mail: <a href="mailto:office@rallye-weiz.at">office@rallye-weiz.at</a>	
Web: <a href="http://www.rallye-weiz.at">http://www.rallye-weiz.at</a>	

## 2.4 ORGANISATION COMMITTEE

Chairman:	Mr. MARIO KLAMMER	(AUT)
Member:	Mr. PETER EIBISBERGER	(AUT)

## 2.5 STEWARDS

Chairman (appointed by the FIA)	Mr. JAROSLAW NOWOROL	(POL)
FIA Steward (appointed by the FIA)	Mr. ALESSANDRO DEGAN	(ITA)
ASN Steward (appointed by the AMF)	Mr. WILHELM SINGER	(AUT)

## 2.6 FIA DELEGATES AND OBSERVER

FIA Sporting Delegate	Mr. JAMIE EDWARDS	(GBR)
FIA Championship Manager	Mr. MATHIAS DOUTRELEAU	(FIA)
FIA Observer	Mr. JOHN MILLINGTON	(GBR)
FIA Eligibility Delegate	Mr. PAT O'DOWD	(IRL)
FIA Media Delegate	Mr. RICHARD RODGERS	(GBR)
FIA Media Delegate / Videographer	Mr. BRYAN TO	(FIA)

## 2.7 SENIOR OFFICIALS

Clerk of the Course	Mr. ANDREAS DINZINGER	(DEU)
Deputy Clerk of the Course	Mr. MARTIN DOHR	(AUT)
Chief Safety Officer	Mr. MARIO KLAMMER	(AUT)
1 <sup>st</sup> Deputy Safety Officer	Mr. PETER EIBISBERGER	(AUT)
2 <sup>nd</sup> Deputy Safety Officers	SAFETY OFFICERS FROM EACH SS	see Bulletin 1
1 <sup>st</sup> Secretary of the Rally (Stewards Secretary)	Mrs. CLAUDIA BIDLAS	(AUT)
Rescue Team Coordination	Team RK WEIZ	(AUT)
Chief Rescue Officer	RK WEIZ	(AUT)
Chief Medical Officer	Dr. SIMONE HOLLOMEY	(AUT)
Deputy Chief Medical Officer	Dr. ELLEN TACKNER	(AUT)
f Scrutineer	Mr. MARTIN SZTACHOVICS-TOMASINI	(AUT)
AMF Scrutineers	Mr. ANTON FASSOLD	(AUT)
	Mr. DIETER KAISER	(AUT)
	Mr. REINHARD LEROCH	(AUT)
	Mr. MANFRED MÄRZINGER	(AUT)
	Mr. ROBERT SAX	(AUT)
AMF Scrutineers Aspirant:	Mr. ERNST HUBER	(AUT)
Press Officer	Mr. ARMIN HOLENIA	(AUT)
Deputy Press Officer	Mr. WOLFGANG NOWAK	(AUT)
Chief of Results System	Mr. DAVOR MALEZIJA	(HRV)
Chief Timekeeper	Mr. DAUT DAMARIJA	(HRV)
1 <sup>st</sup> Competitors' Relations Officer	Mr. PETER GREITER	(AUT)
Service Park Manager	Mr. JOHANN WÜNSCHER	(AUT)
GPS System Officer	Mr. PATRICK SCHRÖTTNER	(AUT)

## 2.8 HQ LOCATION AND CONTACT DETAILS

Rally HQ location from Wednesday 10<sup>th</sup> of July, until Saturday, 13<sup>th</sup> of July 2024

### JUFA HOTEL WEIZ

Dr.-Karl-Widdmann-Straße 46-48,  
A-8160 Weiz  
Tel.: +43 5 70873-21010  
GPS coordinates: N47 13.525 E15 37.293



### 3.2 PROGRAM DURING THE RALLY WEEK

<b>Wednesday, 10<sup>th</sup> of July 2024</b>		
11:00 – 21:30	RALLY HQ opening times	RALLY HQ JUFA HOTEL
11:00 – 15:00 <i>See time schedule in the entry Confirmation on Sportity APP</i>	Registration for Reconnaissance Administrative Checks Collection of Road Book, route map and other documents Collection of Reconnaissance Tracker / GPS Safety System Checking/ Registration of Reconnaissance cars	RALLY HQ JUFA HOTEL WEIZ Dr.-Karl-Widdmann-St. 46-48, A-8160 Weiz
15:00 – 18:00	Reconnaissance see schedule App 2	
<b>Thursday, 11<sup>th</sup> of July 2024</b>		
07:00 – 21:30	RALLY HQ open	RALLY HQ
07:00 – 18:00	Reconnaissance	See Schedule App 2
09:00 09:00	Service Park open Trailer Park open	Dr.Karl-Widdmann-Str. A-8160 Weiz
11:00 – 21:30	Media Centre and Media Accreditation open	RALLY HQ
18:00	Publication of Start List / start blocks for ceremonial start	ONB & VNB
19:00	Exit Service Area for ceremonial start	Service Parc
20:00	Deadline for all cars to arrive at Pre-Start holding area for th ceremonial start	Europa-Allee, Weiz
20:15	<b>CEREMONIAL START</b> Participant presentation / 1 <sup>st</sup> Car	Europa-Allee, A-8160 Weiz
<b>Friday, 12<sup>th</sup> of July 2024</b>		
07:00 – 22:30	RALLY HQ open	RALLY HQ
07:00 – 12:00	Reconnaissance	See Schedule App 2
07:00 – 22:30 07:00 – 22:30	Service Park open Trailer Park open	Area Strobl Company, Dr.Karl-Widdmann-Str.
07:30 – 11:30	Scrutineering - sealing and marking of components	Strobl Company, Dr.Karl-Widdmann-Str.
12:00	Publication of Start List for Leg 1	RALLY HQ ONB / VNB
12:15	GPS System Safety instruction briefing (start ramp)	SEE ALSO ONLINE INFO
<b>13:15</b>	<b>Start Leg 1 / TC 0 / 1<sup>st</sup> Car</b>	Start / Finish Podium in front of Restaurant Strobl, Dr.-Karl-Widdmann Str. 100, A-8160 Weiz
07:00 – 22:30	Media Centre open	RALLY HQ
<b>20:40</b>	<b>Finish Leg 1 / TC 5B</b>	Parc Fermé / RALLY HQ
21:45	Publication of Start List for Leg 2	ONB
<b>Saturday, 13<sup>th</sup> of July 2024</b>		
06:30	Scrutineering of restarting cars / see Art. 12.4.3	Parc Fermé / RALLY HQ
07:00 – 21:30	RALLY HQ open	RALLY HQ JUFA HOTEL WEIZ
07:00 – 21:30	Service Park open Trailer Park open	Area of Company "Strobl" Dr.-Karl-Widdmann-Straße
07:00 – 21:30	Media Centre open	RALLY HQ
<b>07:15</b>	<b>Start of Leg 2 / TC 5C</b>	Parc Fermé / RALLY HQ
19:00	Podium Ceremony and Prize-Giving	Finish Podium
<b>19:30</b>	<b>TC Parc Fermé after finish 1<sup>st</sup> Car</b>	Parc Fermé / RALLY HQ
19:35	Final Scrutineering	Autohaus Jagersberger Dr.-Karl-Widdmann-Straße 67 8160 Weiz
21:15	Publication of Provisional Classification	RALLY HQ , ONB



## INFO EHRC REMOTE SERVICE

### Refuel only on commercial filling stations

### FRIDAY 14. 7. 2023

## INFORMATION EHRC HISTORIC REGULATIONS

### 8.1 SERVICE – GENERAL CONDITIONS

All services made on the car for the duration of the rally must be made in accordance with the EHRC Sporting Regulations, Article 56.

### 8.2 PERMITTED SERVICE LOCATIONS

#### 8.2.1 Service Park

The Service Park is situated at company Strobl Area, Dr. Karl-Widdmannstraße 100-105, A-8160 Weiz  
GPS coordinates: N47 13.713, E 15 37.107 and will be open to the competitors from:  
Thursday, 14th of July 2022 09:00 till Sunday, 17th of July 2022 09:00

#### 8.2.2 Additional Service Zones

Servicing will also be permitted in Remote Service Zones in accordance with EHRC Sporting Regulations Article 60, at the locations indicated in the roadbook as **EHRC REMOTE SERVICE ZONE**.

#### 8.2.3 Procedure in Remote Service Zones

The time for servicing in the Remote Service Zones is included in the sector time. None of the Remote Service Zones include a Refuelling Zone. For safety reasons, refuelling is strictly forbidden in the Remote Service Zones.

### 8.3 FUEL RESTRICTIONS

It is mandatory for participants to use fuel in accordance with FIA Appendix K Article 3.9.

### 8.4 REFUELLING

All Competitors may only refuel in a Refuelling Zone (RZ) in a Remote Refuelling Zone RRZ or in a commercial filling station as indicated in the Road Book.

#### 8.4.1 All Competitors may only refuel in a Refuelling Zone (RZ) as indicated in the Road Book.

Competitors' cars may be refuelled from drums/cans with commercially available fuel and two team members with team passes may access the RZ to assist each crew. In order to access the refuelling zone, team personnel must wear clothing that provides adequate protection against fire and includes at least: long trousers, long-sleeved top, closed shoes, a balaclava and gloves. The use of the Refuelling zone "SERVICE PARC WEIZ" passing on the rally route is on every time allowed. On all Remote Refuel zones the teams is responsible to protect the ground providing an Environmental Mat which will be composed of an absorbent upper part and an impermeable lower part.

**8.4.2 Refuelling in a commercial filling station:**  Refuelling in the commercial filling stations indicated in the Roadbook is allowed. Only the crew itself may refill the car from the commercial fuel pump.

**8.4.3 Refuelling procedure:** The complete refuelling procedure must be in compliance with Article 61.2 of the FIA EHRC Sporting Regulations.

# ÜBERSICHTSPLAN WEIZ OVERVIEW MAP WEIZ

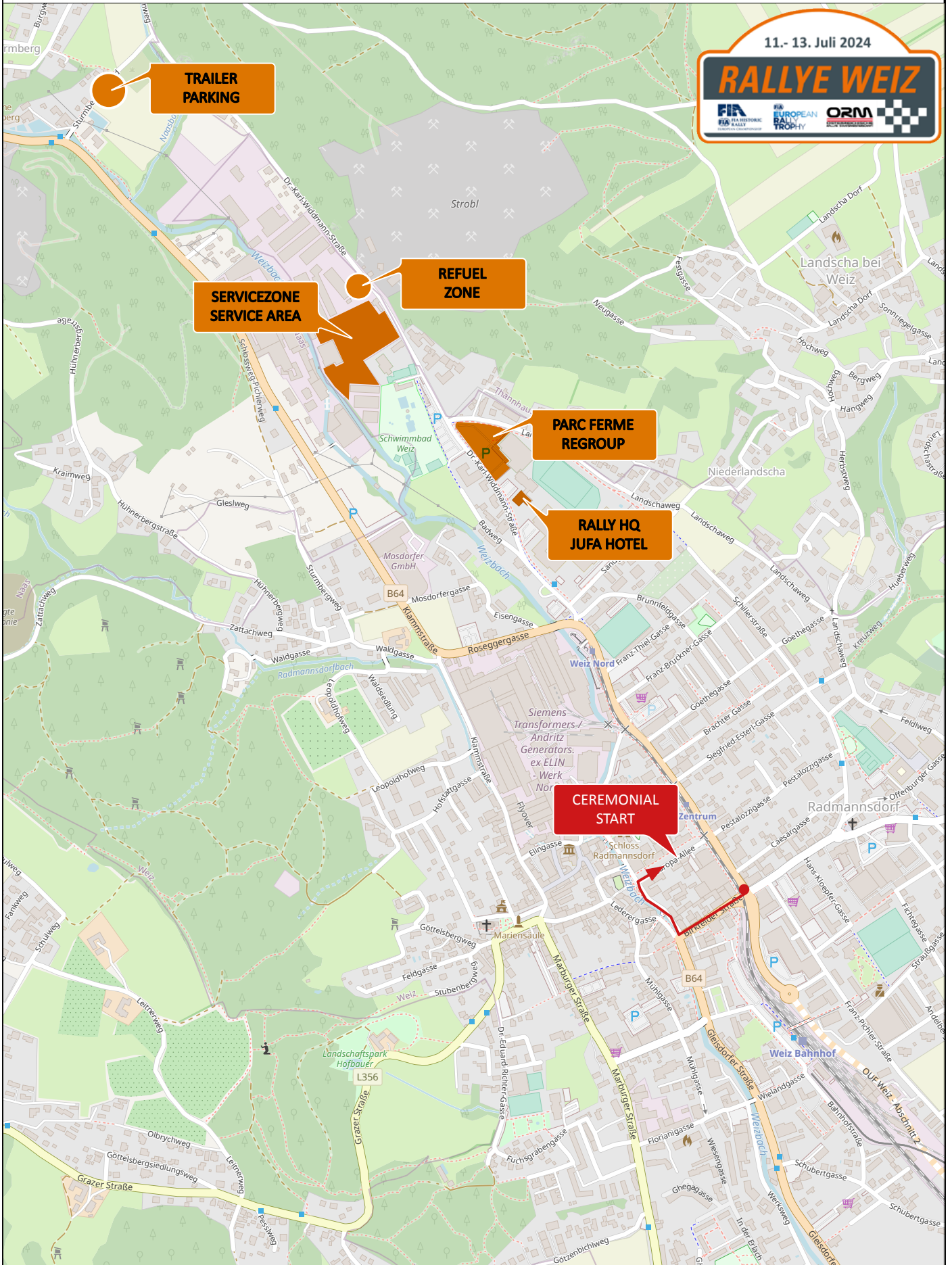

# GPS POSITIONEN / WGS 84

## GPS POINTS / SYSTEM WGS 84

RALLYELEITUNG JUFA HOTEL WEIZ, Roadbookausgabe / Roadbook Issuing, Admin Checks, Presscenter / Mediacenter, offizieller Aushang-notice board.		<b>N 47 13.525 E 15 37.293</b>
<b>SCRUTINEERING</b>		<b>N 47 13.774 E 15 37.060</b>
SERVICE PARC	Gelände Firma Strobl	<b>N 47 13.713 E 15 37.107</b>
TRAILER PARC	Sturmbergweg Süd	N 47 13.903 E 15 36.813
<b>CEREMONIAL START</b>	<b>EUROPA ALLEE WEIZ</b>	<b>N 47 13.122 E 15 37.627</b>
<b>START</b>	<b>ZK/TC 0</b>	<b>N 47 13.698 E 15 37.145</b>
REFUEL ZONE „Service“	Dr. Karl Widdmannstraße	N 47 13.774 E 15 37.060
Oberfeistritz „Hofackerweg“	ZK/TC 1/3	N 47 15.648 E 15 42.123
<b>SP 1/3 Anger Sprint</b>	<b>START</b>	N 47 15.610 E 15 42.111
	<b>FINISH</b>	N 47 24.108 E 15 43.264
	<b>STOP</b>	N 47 24.192 E 15 43.223
<b>EHRC REMOTE SERVICE</b>	<b>Industriestraße 11 Anger</b>	<b>N 47 16.742 E 15 41.572</b>
Strallegg	ZK/TC 2/4	N 47 24.645 E 15 43.537
<b>SP 2/4 Strallegg</b>	<b>START</b>	N 47 24.632 E 15 43.519
	<b>FINISH</b>	N 47 24.089 E 15 43.296
	<b>STOP</b>	N 47 24.143 E 15 43.215
Anger „Südtiroler Platz“	ZK/TC 5	N 47 16.428 E 15 41.490
<b>SP 5 Rundkurs Anger</b>	<b>START</b>	N 47 16.435 E 15 41.455
	<b>FINISH</b>	N 47 15.425 E 15 40.421
	<b>STOP</b>	N 47 15.323 E 15 40.568
REGROUP & PARC FERME IN REGROUP & PARC FERME OUT	ZK/ TC 3A, 5B, 9A, 11A, 13A ZK/ TC 3B, 5C, 9B, 11B	<b>N 47 13.578 E 15 37.251</b>
SERVICE OUT / STROBL-WEIZ	ZK/ TC 3C, 5D, 9C	N 47 13.686 E 15 37.122
Kickhof	ZK/TC 6/8	N 47 14.937 E 15 40.900
<b>SP 6/8 Thannhausen</b>	<b>START</b>	N 47 14.892 E 15 40.910
	<b>FINISH</b>	N 47 14.489 E 15 38.417
	<b>STOP</b>	N 47 14.400 E 15 38.383
Kreuzwirt	ZK/TC 7/9	N 47 11.770 E 15 30.968
<b>SP 7/9 Gollersattel</b>	<b>START</b>	N 47 11.807 E 15 30.963
	<b>FINISH</b>	N 47 14.833 E 15 30.867
	<b>STOP</b>	N 47 14.942 E 15 30.742
Naas Dorf	ZK/TC 10/12	N 47 14.844 E 15 36.255
<b>SP 10/12 Rundkurs Naas</b>	<b>START</b>	N 47 14.882 E 15 36.238
	<b>FINISH</b>	N 47 14.680 E 15 30.017
	<b>STOP</b>	N 47 14.894 E 15 36.080
Bucklige Lärche	ZK/TC 2/4	N 47 21.095 E 15 35.647
<b>SP 11/13 Koglhof</b>	<b>START</b>	N 47 21.168 E 15 35.534
	<b>FINISH</b>	N 47 11.800 E 15 30.950
	<b>STOP</b>	N 47 19.967 E 15 41.000
<b>HOLDING / ZIEL / FINISH</b>	ZK/ TC 13A ZK/ TC 13B	N 47 13.581 E 15 37.216 N 47 13.698 E 15 37.145
<b>PARC FERME IN</b>	<b>ZK/TC 13C</b>	<b>N 47 13.578 E 15 37.251</b>
<b>FINISH SCRUTINEERING</b>	<b>Autohaus Jagersberger Dr.-Karl-Widdmann-Straße 67, 8160 Weiz</b>	<b>N 47 13.692 E 15 37.159</b>

11.- 13. Juli 2024

# RALLYE WEIZ



## SERVICE PARC STROBL COMPANY

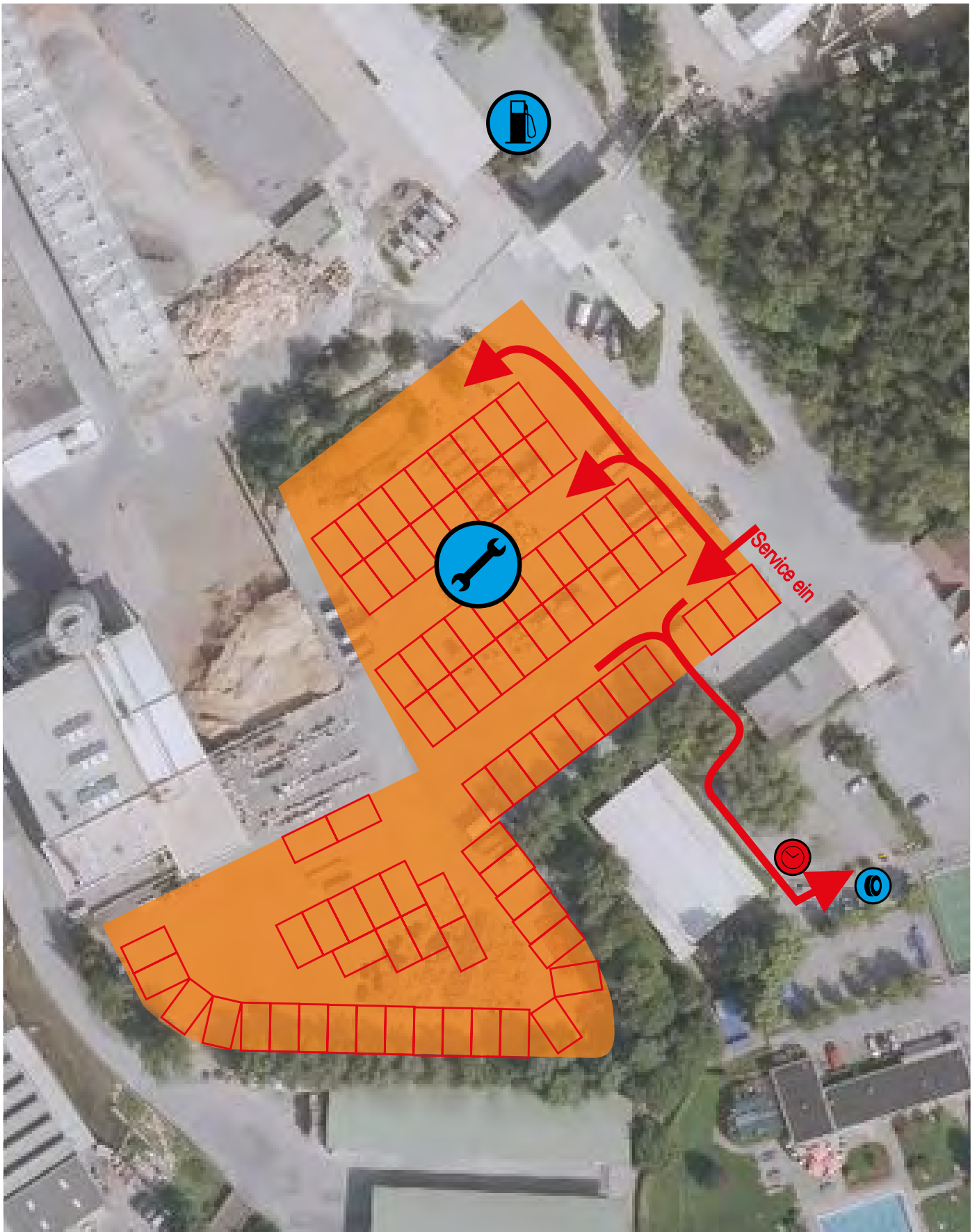





**SERVICE-ZONES WEIZ**

**REFUEL WEIZ**

GPS: N 47 16.740 E 15 41.633  
 ° min. sec. N 47 16 44 E 15 41 38

**FOR SAFETY REASONS - REFUELLING AT THE SERVICE AREA BEFORE THE RALLY START IS FORBIDDEN**

SERVICE „A“ after SS 1/2/3	<b>30 Minutes</b>		<input style="width: 90%; height: 20px;" type="text"/>
SERVICE „B“ after SS 5	<b>45 Minutes</b>		<input style="width: 90%; height: 20px;" type="text"/>
SERVICE „C“ after Parc Ferme	<b>10 Minutes</b>		<input style="width: 90%; height: 20px;" type="text"/>
SERVICE „D“ after SS 7	<b>20 Minutes</b>		<input style="width: 90%; height: 20px;" type="text"/>
SERVICE „E“ after SS 9	<b>30 Minutes</b>		<input style="width: 90%; height: 20px;" type="text"/>
SERVICE „F“ after SS 11	<b>20 Minutes</b>		<input style="width: 90%; height: 20px;" type="text"/>

**NO SERVICE OUTSIDE THE SERVICEPARCS EXEPT REMOTE SERVICE ANGER IS ALLOWED**  
 IN ANY CASE, OBSERVE THE REQUIREMENTS OF THE EHRC REGULATIONS „SERVICE & REFUELING“

**OUTSIDE REFUELLING ONLY ON COMMERCIAL FILLING STATIONS**

**OUTSIDE REFUELLING IS ONLY ALLOWED ON COMMERCIAL FILLING STATIONS Art 61.3**

61.3 Drivers may use commercially available pump fuel dispensed from pumps at commercial filling stations indicated in the roadbook. This fuel must be dispensed directly into the tank of the competing car.

61.3.2 The crew must use solely the equipment on board and only the pumps with no external physical assistance.

61.3.3 Cars equipped only with FIA-specified refuel couplings and using fuel from commercial fillings stations must transport the adaptor in the car and show it at pre-rally scrutineering.

**REGROUP / HOLDING ZONE INFO**

**NO SERVICE OR WORKING ON THE CARS IS IN THE REGROUPS ALLOWED**  
 To bring and pick up the rallycar by Service Crew including timecard is allowed on TC 5B & TC 5C

REGROUP after SS 3	<b>30 Minutes</b>	REGROUP after SS 9	<b>90 Minutes</b>
REGROUP after SS 11	<b>20 Minutes</b>	HOLDING ZONE after SS13	<b>ca. 20 Minutes</b>

# STAGES FRIDAY

## STAGES SATURDAY

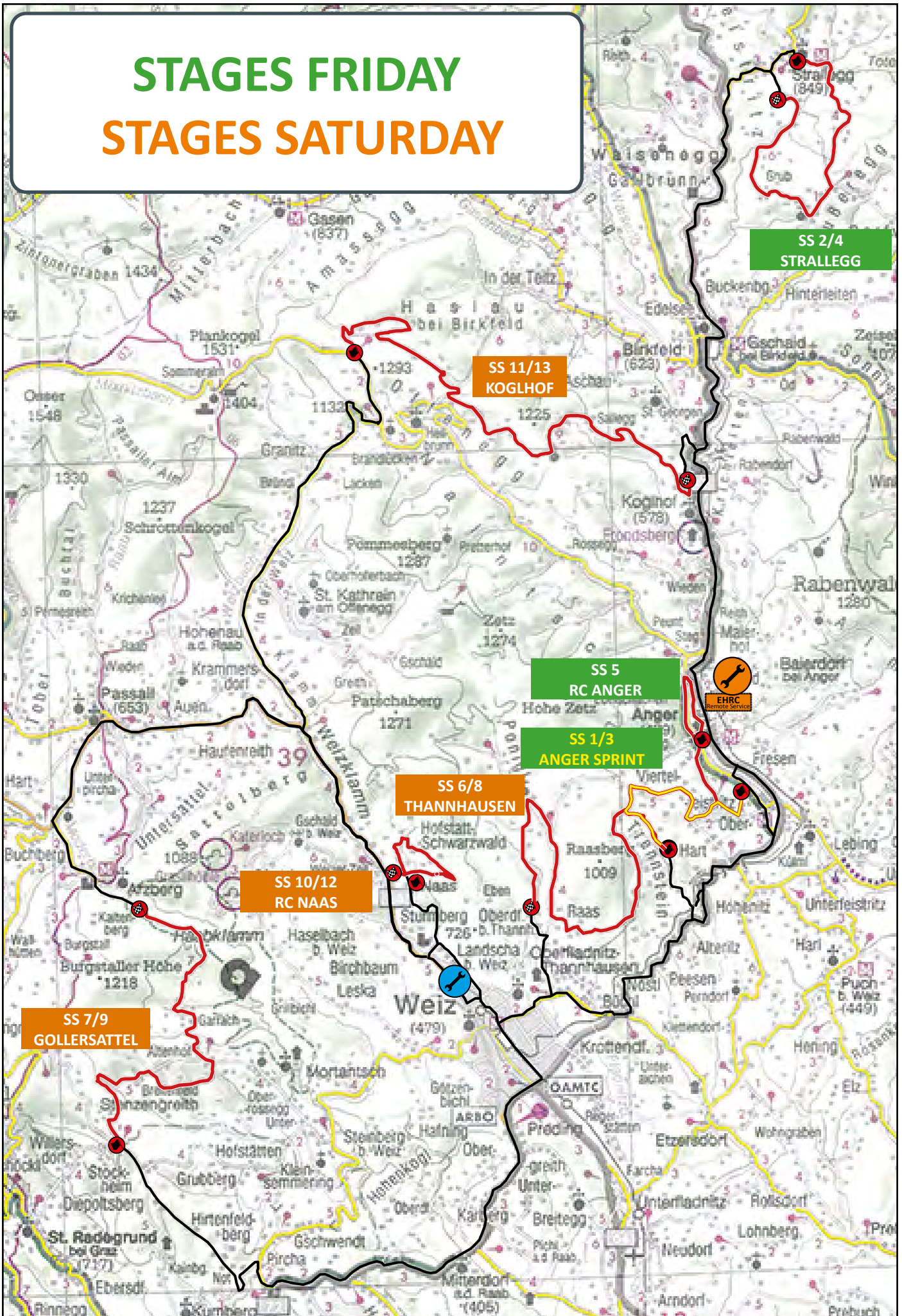

SS 2/4  
STRALLENGG

SS 11/13  
KOGLHOF

SS 5  
RC ANGER

SS 1/3  
ANGER SPRINT

SS 6/8  
THANNHAUSEN

SS 10/12  
RC NAAS

SS 7/9  
GOLLERSATTEL



# RECOMMENDED ORDER OF RECCE

To save time we recommended following recce ordering.

The first two passages to write and control first.

The third passage to check the notes

You can combine two or three stages in a recce block see recommended Blocks.

## !! NOTE THE SPECIAL STAGES ARE NOT CLOSED FOR RECCE !!

Therefore, individual traffic and especially oncoming traffic is to be expected at any time. Parts of special stages will also be driven several times as different stages. This concerns the circuit Special Stages Anger and Anger Sprint. **On the special stage Thannhausen is at the beginning of the Stage (0,0 - 1,76 km) at the same track the final part of the Anger Stages from Friday in the opposite direction, here we ask for special caution**

### DON'T DRIVE AT RECCE ALL STAGES OR PARTS IN OPPOSITE DIRECTION

**9.4.3 Direction** Each crew may drive the Special Stages only in the direction of the rally. The crews must always enter and leave the Special Stages through the start and stop controls.

**FOR GOOGLE MAP GPS ROUTES  
CLICK ON THE COLORED TEXTLINK**

**STAGE FROM START TO FINISH  
TO STAGE START / FINISH  
CORRECT ROUTE FROM STAGE STOP TO STAGE START**

STAGE	BLOCK 1	MAP	MAP
<b>*STAGE 5</b>	<b>RC ANGER</b>	<a href="#">Start</a>	<a href="#">from stop SS back to start</a>
<a href="#">STAGE 1/3</a>	<b>ANGER SPRINT</b>	<a href="#">Start</a>	<a href="#">from stop SS back to start</a>
<a href="#">STAGE 6/8</a>	<b>THANNHAUSEN</b>	<a href="#">Start</a>	<a href="#">from stop SS back to start</a>
<b>STAGE</b>	<b>BLOCK 2</b>	<b>MAP</b>	<b>MAP</b>
<a href="#">STAGE 11/13</a>	<b>KOGLHOF</b>	<a href="#">Start</a>	<a href="#">from stop SS back to start</a>
<a href="#">STAGE 2/4</a>	<b>STRALLEGG</b>	<a href="#">Start</a>	<a href="#">from stop SS back to start</a>
<b>STAGE</b>	<b>BLOCK 3</b>	<b>MAP</b>	<b>MAP</b>
<a href="#">STAGE 7/9</a>	<b>GOLLERSATTEL</b>	<a href="#">Start</a>	<a href="#">from stop SS back to start</a>
<a href="#">STAGE 10/12</a>	<b>RC NAAS</b>	<a href="#">Start</a>	<a href="#">Finish</a>

\*Due to a map error on Google Maps, the SS 5 cannot be displayed as a complete route.



# RECCE & GPS CONTROLLING INFO

Each crew is limited to 3 passages on each Special Stage.  
 Special Stages run twice are considered to be one Special Stage.  
 The recce is controlled by GPS monitoring system see supplementary regulations Art. 9

10.07.2024, 15:00 – 20:00	Special Stages 1-13
11.07.2024, 07:00 – 18:00	Special Stages 1-13
12.07.2024, 07:00 – 12:00	Special Stages 1-13

## APPENDIX 3. COMPETITORS' RELATIONS OFFICERS

**9.4 RECONNAISSANCE RULES** The crews are obliged to follow all reconnaissance rules specified in FIA EHRC Sporting Regulations and these Supplementary Regulations.

**9.4.1 Reconnaissance** Reconnaissance will be organised in compliance with art. 35 of FIA EHRC Sporting Regulations and only series production cars conforming to art. 35.1 of FIA EHRC Sporting Regulations must be used.

**9.4.2 Speed limit (Art. 34.2 of FIA EHRC Sporting Regulations):** The maximum speed set for the reconnaissance of the SS is according to the Austrian traffic laws 100 km/h, except for those areas in which there are speed limit signs or in built-up areas 50 km/h or 30 km/h or other limitations marked in the Road Book.

**9.4.3 Direction** Each crew may drive the Special Stages only in the direction of the rally. The crews must always enter and leave the Special Stages through the start and stop controls.

**9.4.4 Restriction of reconnaissance** Any driver, or his co-driver, or any other team member who has entered or intends to enter the rally and who wishes to drive 3 months ahead the rally on any road which is or might be used as a Special Stage in that rally, may only do so after he has obtained written permission from Clerk of the Course. Failure to respect this rule shall result in the driver being reported to the Stewards.

**9.4.5 Number of persons on board** During each passage through a Special Stage, a maximum of 2 persons (the crew) are permitted in the car.

**9.4.7 Illegal reconnaissance** Illegal reconnaissance performed out of the official time schedule or performing more passages than permitted will be reported to the stewards.

**9.4.8 Speeding** Speeding will be penalized according to the Art. 34.2 of FIA EHRC Sporting Regulations. Speeding during reconnaissance will incur a fine applied by the clerk of the course as follows - per km per hour over the speed limit: all drivers EUR 25,00. The fine will be doubled in case of a second offence committed during reconnaissance.

**9.4.9 Radar detection equipment** The fitting or carrying of radar detection equipment during reconnaissance is not permitted. Infringements will be reported to the stewards.

### Speed checking during the reconnaissance

During reconnaissance the crew is obliged to follow traffic rules of Austria. Not respecting this rule, especially exceeding the speed limits, will be monitored via ONI® tracking system. This checking doesn't exclude other checks, i.e. police controls according to their standard procedures.

### ONI® tracking system for reconnaissance

Tracking system is checking the speed in every moment during the reconnaissance. Every crew will pick up the ONI® recce tracking unit together with roadbook. Installation of the unit and using during reconnaissance is obligatory for all crews during the whole schedule of reconnaissance according to the art. 3 Reconnaissance schedule. For speed checking during the reconnaissance, NCL 21 units are used.



Itinerary - Zeitplan Rallye Weiz 2024 (EHRC & ERT)						
CEREMONIAL START		Sunrise 05:17	Sunset 20:49	THURSDAY 11/07/24		
TC	Location	Informations			First car due	
CS IN	Europa Allee Weiz	Exit Service see time on CS-time card			19:00	
CS	CEREMONIAL START RAMP	consider order from CS start list			20:15	
Leg 1 / Etappe 1		Sunrise 05:17	Sunset 20:49	FRIDAY 12/07/24		
TC	Location	SS-dist.	Liasion-dist.	Total-dist.	Target time	First car due FIA EHRC
RZ1	Tankzone / Refuel all Competitors	0,00	0,00	0,00	CONSIDER ART. 61 REFOEL & Art. 61.2.3 "SAFETY CLOTHING"	
	Distance to next Refuel	21,62	77,88	99,50		
0	Start "GH Strobl WEIZ"					<b>13:15</b>
1	Oberfeistritz / Hofackerweg		13,81	13,81	27	13:42
SS1	Anger-Sprint I	5,56				<b>13:45</b>
	<u>EHRC RSZ Anger (refuel only at petrol stations indicatet in the roadbook)</u>				max 15 min	
2	Strallegg		29,80	35,36	57	14:42
SS2	Strallegg I	10,50				<b>14:45</b>
	<u>EHRC RSZ Anger (refuel only at petrol stations indicatet in the roadbook)</u>				max 15 min	
3	Oberfeistritz / Hofackerweg		23,03	33,53	57	15:42
SS3	Anger-Sprint II	5,56				<b>15:45</b>
3A	Regroup IN Weiz		10,43	15,99	30	16:15
	<u>Regroup Weiz</u>				30	
3B	Regroup OUT - Service IN		0,16	0,16		16:45
EHRC-ERT SERVICE A "Service Park Weiz"		21,62	77,23	98,85	<b>30</b>	
3C	Service OUT		0,65	0,65		17:15
RZ2	Tankzone / Refuel all Competitors	21,62	77,88	99,50	CONSIDER ART. 61 REFOEL & Art. 61.2.3 "SAFETY CLOTHING"	
	Distance to next Refuel	29,82	70,41	100,23		
4	Strallegg		38,82	38,82	52	18:07
SS4	Strallegg II	10,50				<b>18:10</b>
	<u>EHRC RSZ Anger (refuel only at petrol stations indicatet in the roadbook)</u>				max 15 min	
5	Anger		21,12	31,62	57	19:07
SS5	SSS Anger (3 rounds)	19,32				<b>19:10</b>
5A	Service IN		10,47	29,79	45	19:55
EHRC-ERT SERVICE B "Service Park Weiz"		29,82	71,06	100,88	<b>45</b>	
RZ3	Tankzone / Refuel all Competitors	29,82	71,06	100,88	CONSIDER ART. 61 REFOEL & Art. 61.2.3 "SAFETY CLOTHING"	
	Distance to next Refuel	0,00	1,81	1,81		
5B	Parc Fermè in "Early check-in permitted"		1,00	1,00		20:40
<b>SAFETY INFORMATION REMINDER! ACTIVATE THE EXTINGUISHER SYSTEMS IN PARC FERME</b>						
Etappe 1		51,44	149,29	200,73		

**Exemptions for TC 5B:** It is the service Crew allowed to bring the race car from the Service and passing the TC 5B to the correct time including to hand over the timecard for the competitor.

**Exemptions for TC 5C:** It is the service Crew allowed to pick up the race car from the Parc fermè and passing the TC 5C to the correct time including to take over the timecard for the competitor.

**Ausnahmen für TC 5B:** Es ist der Service-Crew gestattet, das Rennfahrzeug vom Service zu bringen und die TC 5B zur richtigen Zeit zu passieren, einschließlich der Übergabe der Zeitkarte für den Teilnehmer.

**Ausnahmen für TC 5C:** Es ist der Service-Crew gestattet, den Rennwagen vom Parc fermè abzuholen und die TC 5C zur korrekten Zeit zu passieren, einschließlich der Übernahme der Zeitkarte für den Teilnehmer.

11.- 13. Juli 2024

# RALLYE WEIZ



## MAP - FRIDAY

# 12.07.2024

## Section 1 SS 1-3

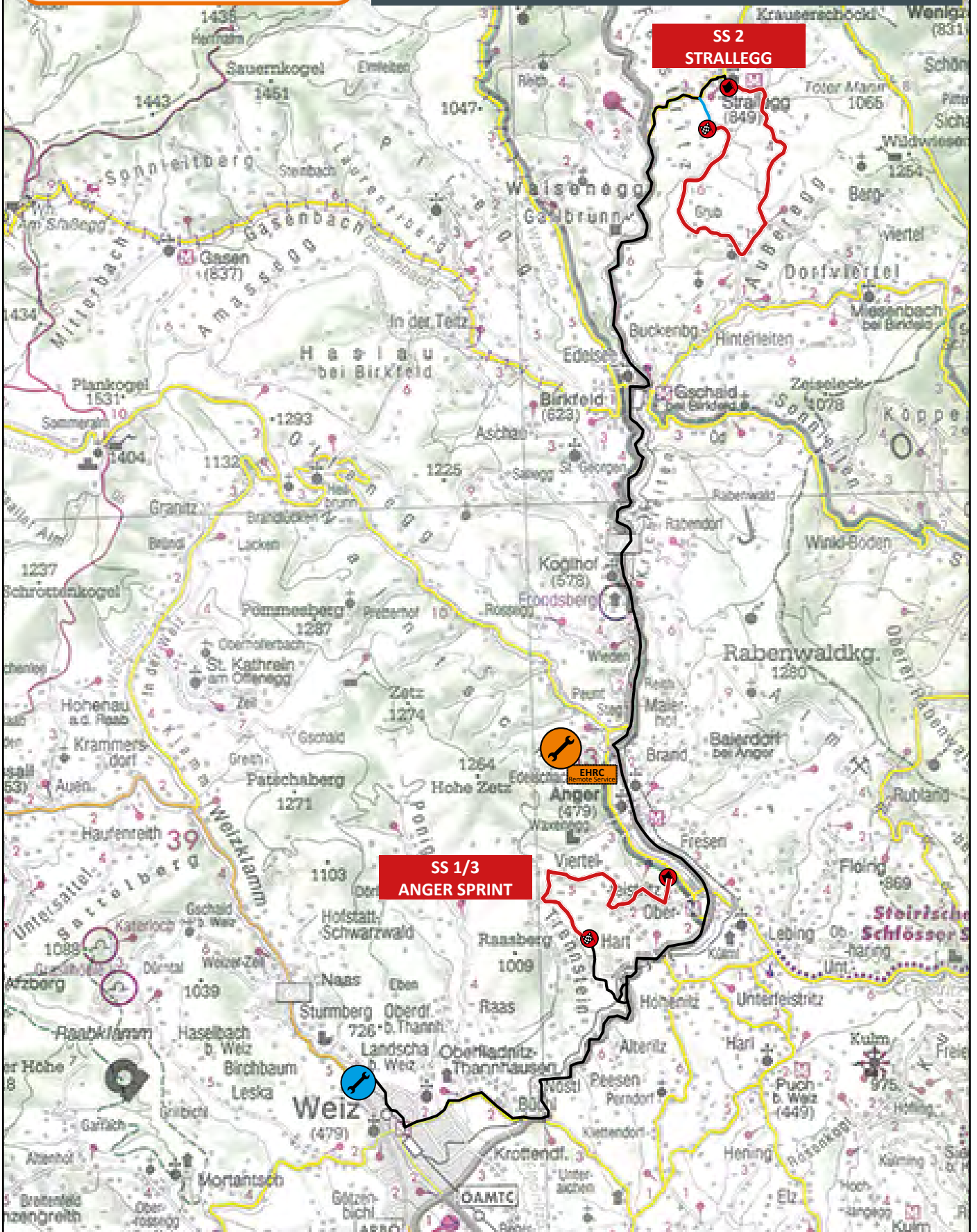

# SP/SS 1/3 ANGER-SPRINT

5,60 km

Friday 12.7.2024

the route is ident 2023

11.- 13. Juli 2024

## RALLYE WEIZ

FIA  
FIA HISTORIC  
RALLY

FIA  
EUROPEAN  
RALLY  
TROPHY

ORM  
OFFICIAL RACING ORGANIZATION



[www.rallye-weiz.at](http://www.rallye-weiz.at)

EHRC-REMOTE SERVICE  
REFUEL ANGER

OLD STAGE  
PART (1,10 km)

NEW PART  
2023

STOP

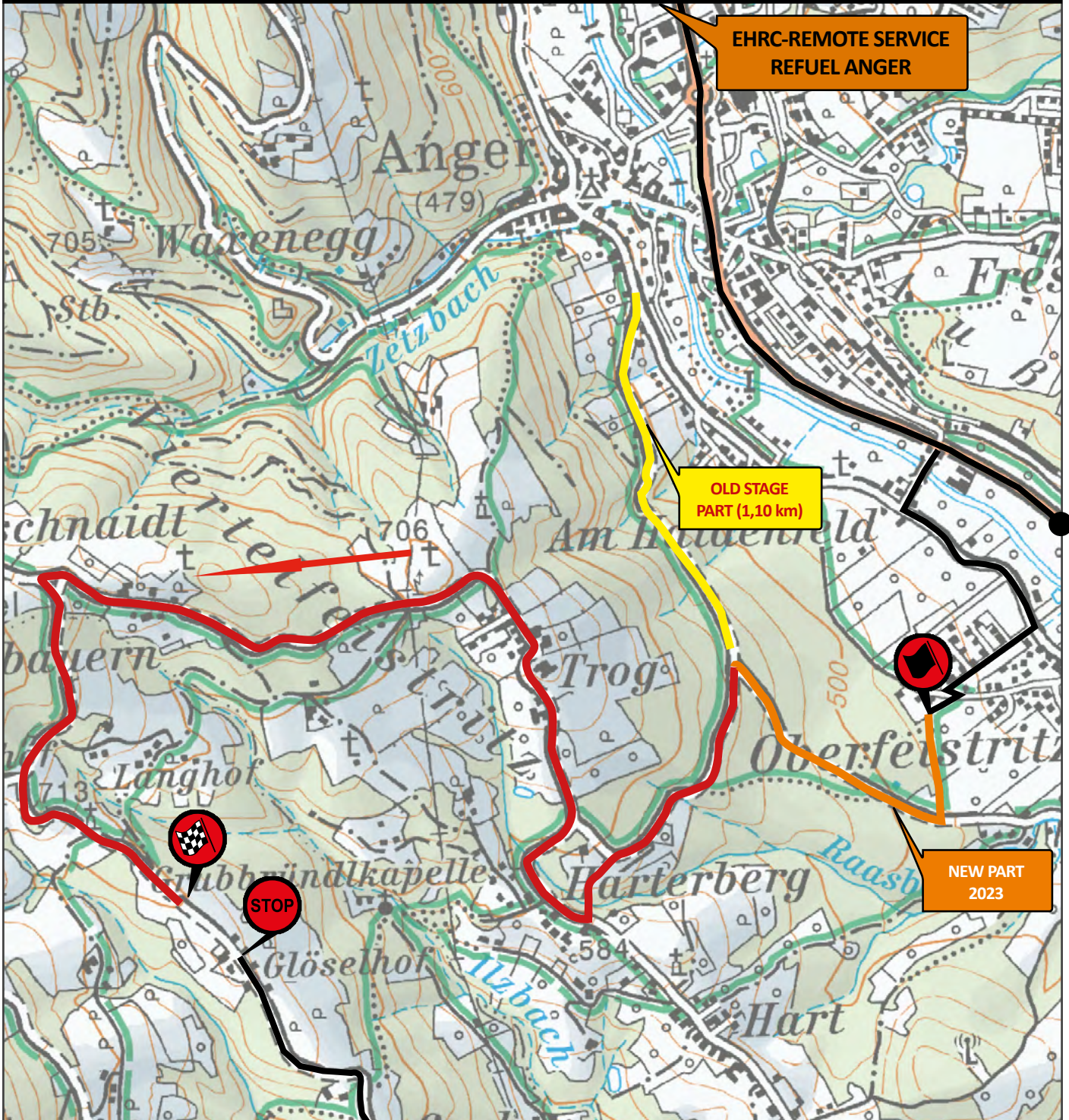

Bereichswerte: Entfernung: 986 m Höhendifferenz: 107 m, -212 m Maximale Steigung: 39,3% -30,9% Durchschnittliche Steigung: 11,5% -8,5%



11.- 13. Juli 2024

# RALLYE WEIZ











## EHRC REMOTE SERVICE

### Transporte Haidenbauer

Industriestraße 11 A-8184 Anger  
N 47 16.747 / E 15 41.581

**CALCULATE THE SERVICE TIME IN THE SECTION TIME „SR ART. 8.2.3“**

**OUTSIDE REFUEL IS ONLY ON COMMERCIAL FILLING STATIONS ACCORDING ART. 61.3 ALLOWED**

after SS1 to SS2 = _____ Minutes (max. 15)	<input type="text"/>	<input type="text"/>			
after SS2 to SS3 = _____ Minutes (max. 15)	<input type="text"/>	<input type="text"/>			
after SS4 to SS5 = _____ Minutes (max. 15)	<input type="text"/>	<input type="text"/>			

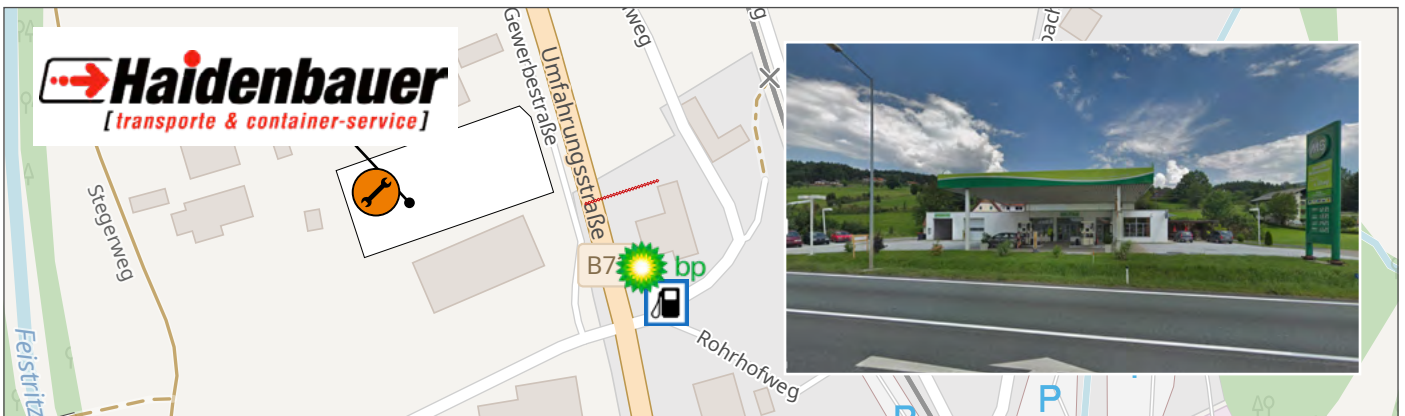



# SP/SS 2/4 Strallegg

10,50 km

Friday 12.7.2024

Route is ident with the years 2020, 21 & 23

11.- 13. Juli 2024

## RALLYE WEIZ

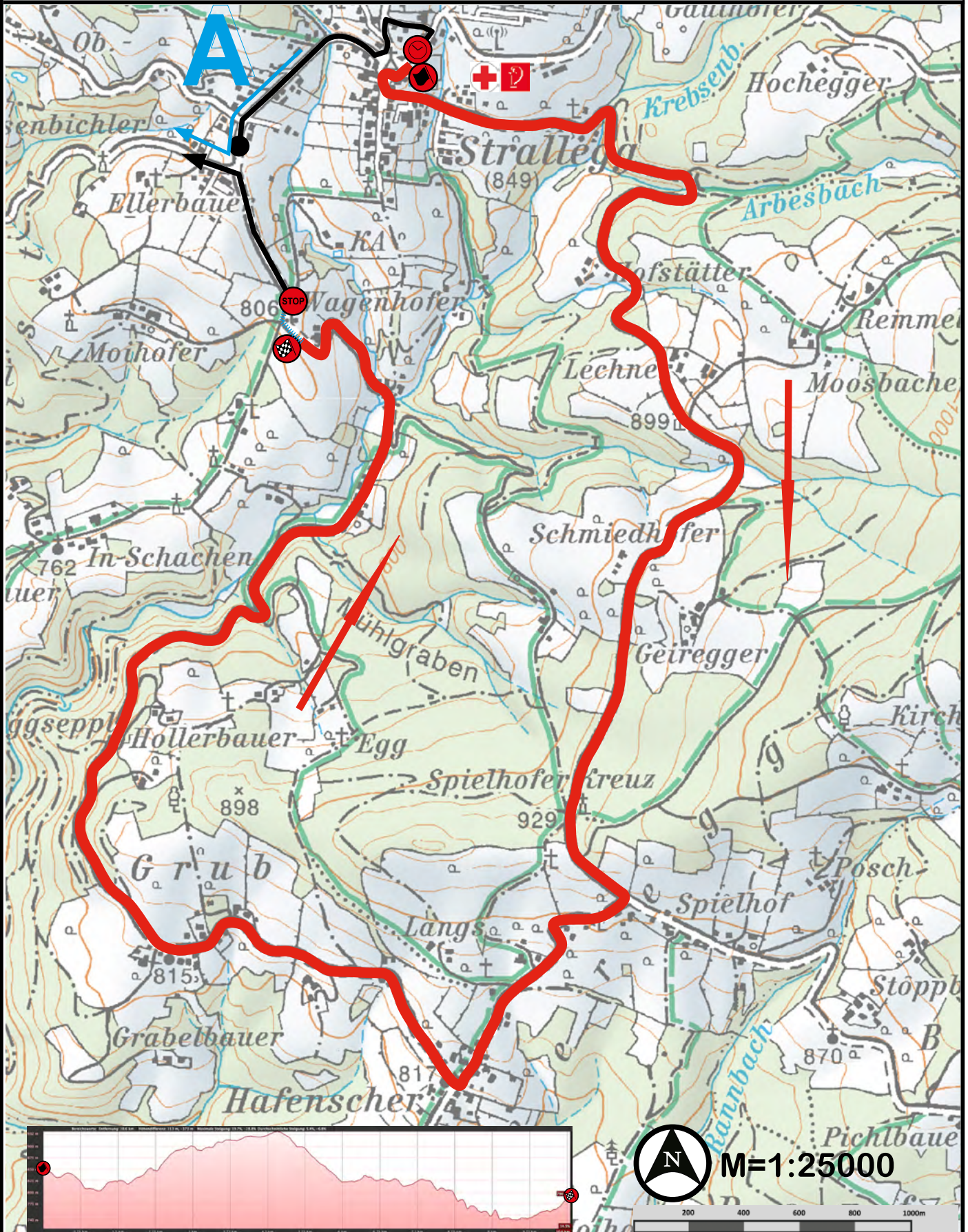

11.- 13. Juli 2024

# RALLYE WEIZ



## MAP - FRIDAY

# 12.07.2024

## Section 2 SS 4-5

**SS 4  
STRALLEGG**

**SS 5  
ANGER RUNDKURS**



# SP/SS 5 RC ANGER

19,32 km

Friday 12.7.2024

Route ident 2021-23 ! + one round more

11.- 13. Juli 2024

## RALLYE WEIZ



[www.rallye-weiz.at](http://www.rallye-weiz.at)

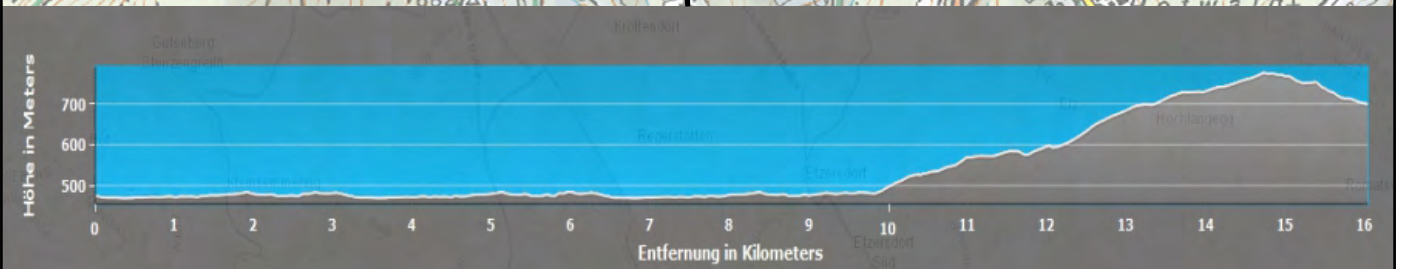
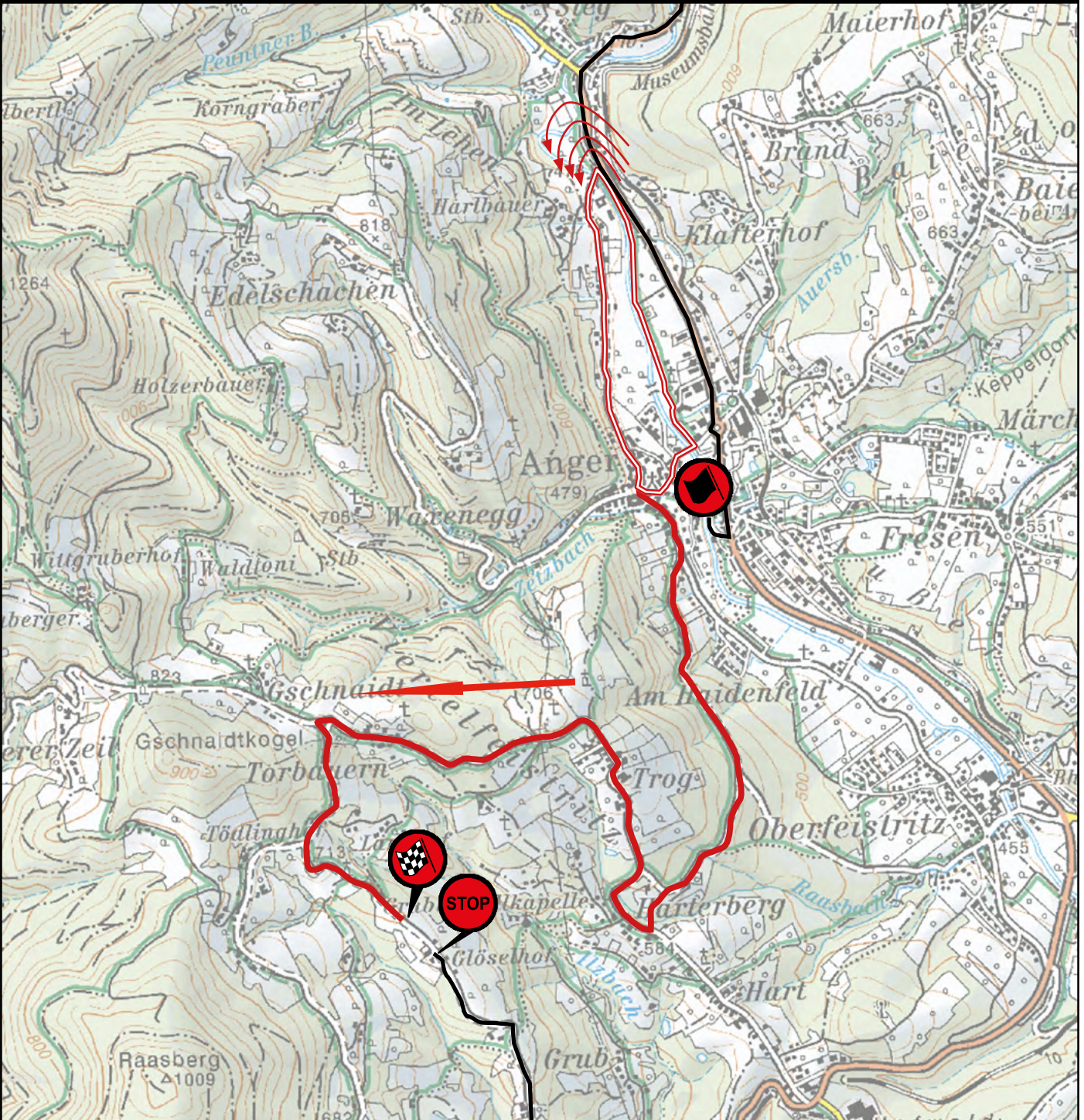

Min.: 469 Max.: 776 Start: 473 Ende: 700 Änderung: 227

Itinerary - Zeitplan Rallye Weiz 2024 (EHRC & ERT)						
Leg 2 / Etappe 2		Sunrise 05:18		Sunset 20:48		SATURDAY 13/07/24
TC	Location	SS-dist.	Liasion-dist.	Total-dist.	Target time	First car due FIA EHRC
5C	<b>PARC FERMÉ OUT / SERVICE IN</b>		0,16	0,16		<b>07:15</b>
	EHRC-ERT SERVICE C "Service Park Weiz"		<b>1,16</b>	<b>1,16</b>	<b>10</b>	
5D	Service OUT		0,65	0,65		07:25
<b>RZ 4</b>	Tankzone / Refuel all Competitors	0,00	1,81	1,81	Consider Art. 61 REFUEL & Art. 61.2.3 "SAFETY"	
	Distance to next Refuel	25,38	52,99	78,37		
6	Kick Hof		12,43	12,43	22	07:47
<b>SS 6</b>	<b>Thannhausen I</b>	<b>12,54</b>				<b>07:50</b>
7	Kreuzwirt		21,39	33,93	62	08:52
<b>SS 7</b>	<b>Gollersattel I</b>	<b>12,84</b>				<b>08:55</b>
7A	Service IN		18,52	31,36	50	09:45
	EHRC-ERT SERVICE D "Service Park Weiz"		<b>25,38</b>	<b>52,99</b>	<b>78,37</b>	<b>20</b>
7B	Service OUT		0,65	0,65		10:05
<b>RZ 5</b>	Tankzone / Refuel all Competitors	25,38	52,99	78,37	Consider Art. 61 REFUEL & Art. 61.2.3 "SAFETY"	
	Distance to next Refuel	25,38	53,84	79,22		
8	Kick Hof		12,43	12,43	22	10:27
<b>SS 8</b>	<b>Thannhausen II</b>	<b>12,54</b>				<b>10:30</b>
9	Kreuzwirt		22,08	34,62	62	11:32
<b>SS 9</b>	<b>Gollersattel II</b>	<b>12,84</b>				<b>11:35</b>
9A	Regroup IN Weiz		18,52	31,36	50	12:25
	Regroup Weiz				100	
9B	Regroup OUT / Service IN		0,16	0,16		14:05
	EHRC-ERT SERVICE E "Service Park Weiz"		<b>25,38</b>	<b>53,84</b>	<b>79,22</b>	<b>30</b>
9C	Service OUT		0,65	0,65		14:35
<b>RZ 6</b>	Tankzone / Refuel all Competitors	25,38	53,84	79,22	Consider Art. 61 REFUEL & Art. 61.2.3 "SAFETY"	
	Distance to next Refuel	25,00	44,80	69,80		
10	Naas-Dorf		3,07	3,07	12	14:47
<b>SS 10</b>	<b>RK Naas I</b>	<b>10,76</b>				<b>14:50</b>
11	Bucklige Lärche		16,38	27,14	42	15:32
<b>SS 11</b>	<b>Koglhof I</b>	<b>14,24</b>				<b>15:35</b>
11A	Regroup IN Weiz		24,54	38,78	50	16:25
	Regroup Weiz				20	
11B	Regroup OUT / Service IN		0,16	0,16		16:45
	EHRC-ERT SERVICE F "Service Park Weiz"		<b>25,00</b>	<b>44,80</b>	<b>69,80</b>	<b>20</b>
11C	Service OUT		0,65	0,65		17:05
<b>RZ 7</b>	Tankzone / Refuel all Competitors	25,00	44,80	69,80	Consider Art. 61 REFUEL & Art. 61.2.3 "SAFETY"	
	Distance to next Refuel	25,00	44,97	69,97		
12	Naas-Dorf		3,07	3,07	12	17:17
<b>SS 12</b>	<b>RK Naas II</b>	<b>10,76</b>				<b>17:20</b>
13	Bucklige Lärche		16,38	27,14	42	18:02
<b>SS 13</b>	<b>Power Stage Koglhof II</b>	<b>14,24</b>				<b>18:05</b>
13A	Holding Zone IN		24,54	38,78	50	18:55
	Holding Zone (sorting for finish EHRC "10-1") (sorting for finish place ERT "15-1")				10	
13B	Holding Zone OUT		0,16	0,16		19:05
	<b>Finish Ramp Podium GH Strobl</b>					<b>19:05</b>
13C	Parc Fermé In "Early check-in permitted"		0,82	0,82	5	19:10
	<b>SAFETY INFORMATION REMINDER! ACTIVATE THE EXTINGUISHER SYSTEMS IN PARC FERME</b>					
	Etappe 2 - Etappe 2 totals		<b>100,76</b>	<b>197,41</b>	<b>298,17</b>	
<b>TOTALS OF THE RALLY</b>						
		<b>SS</b>	<b>Liasion</b>	<b>Total</b>	<b>% of Special Stages</b>	
Day 1 -	5 SS	51,44	149,29	200,73		25,63%
Day 2 -	8 SS	100,76	197,41	298,17		33,79%
		<b>152,20</b>	<b>346,70</b>	<b>498,90</b>		<b>30,51%</b>

Section 3

Section 4

Section 5

Sec.5b

11.- 13. Juli 2024

# RALLYE WEIZ



## MAP - SATURDAY

# 13.07.2024

## Section 3 SS 6-9

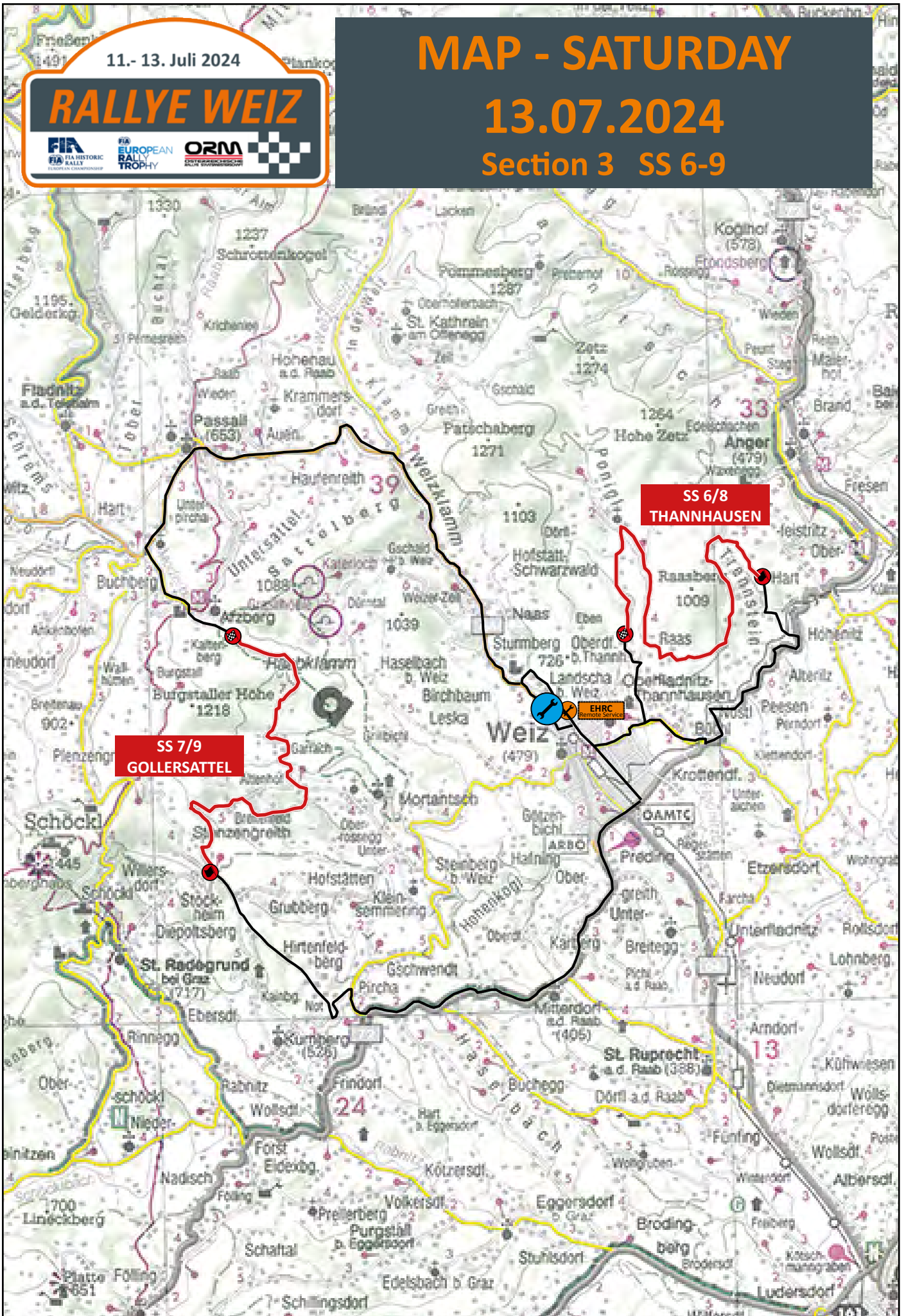

**SS 6/8  
THANNSHAUSEN**

**SS 7/9  
GOLLERSATTEL**



# SP/SS 6/8 Thannhausen

12,54 km

Saturday 13.7.2024

Route is ident with the years 2021 - 2023

11.- 13. Juli 2024

## RALLYE WEIZ



[www.rallye-weiz.at](http://www.rallye-weiz.at)

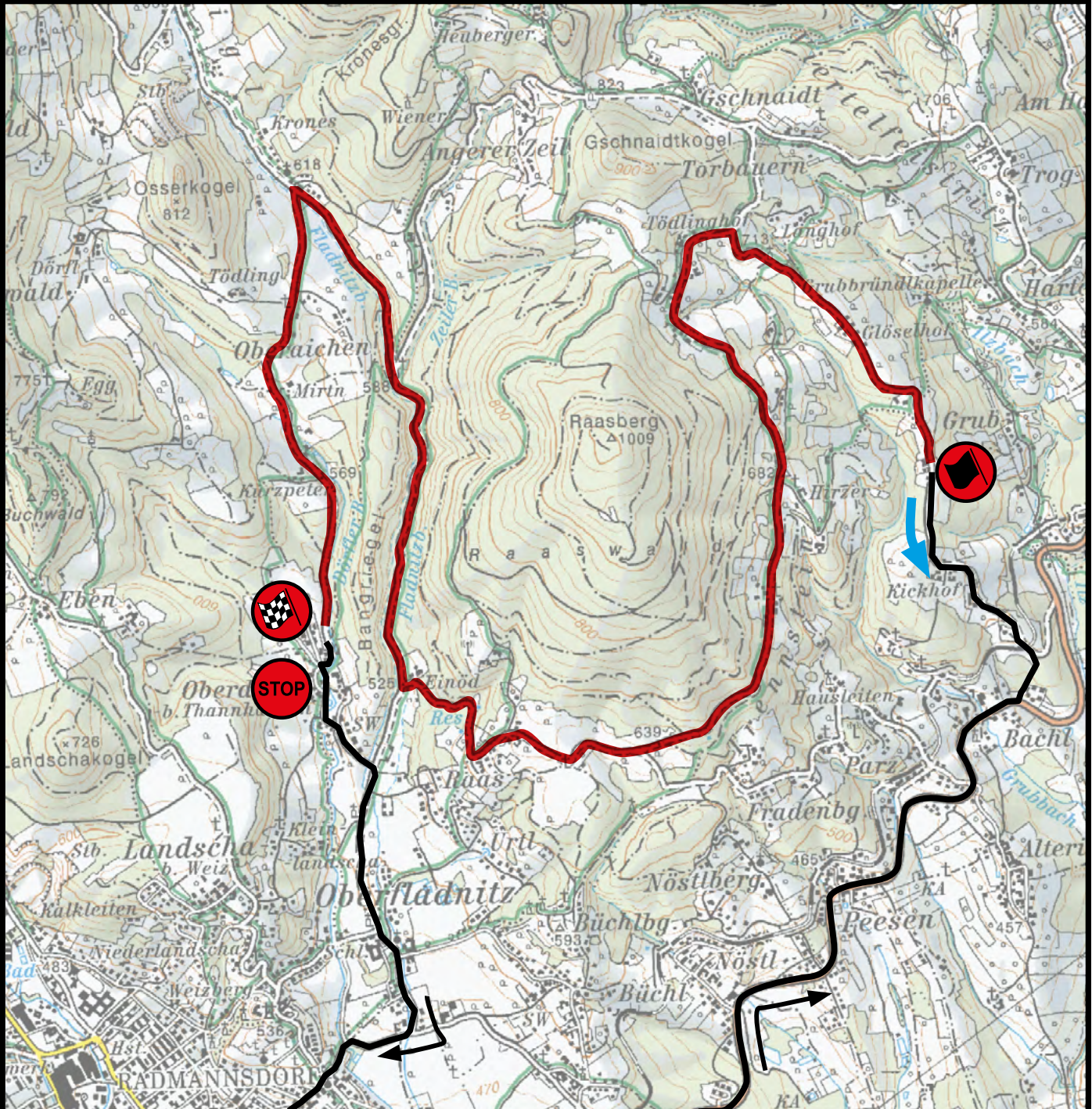

Grafik: Min., Durchschnitt, Max. Höhe: 527, 638, 772 m  
Bereichswerte: Entfernung: 12,4 km Höhendifferenz: 514 m, -581 m Maximale Steigung: 32,1%, -29,9% Durchschnittliche Steigung: 6,9%, -7,8%



# SP/SS 7/9 Gollersattel

12,68 km

Saturday 13.7.2024

Route is ident with the years 2021 - 2023

11.-13. Juli 2024

## RALLYE WEIZ



[www.rallye-weiz.at](http://www.rallye-weiz.at)

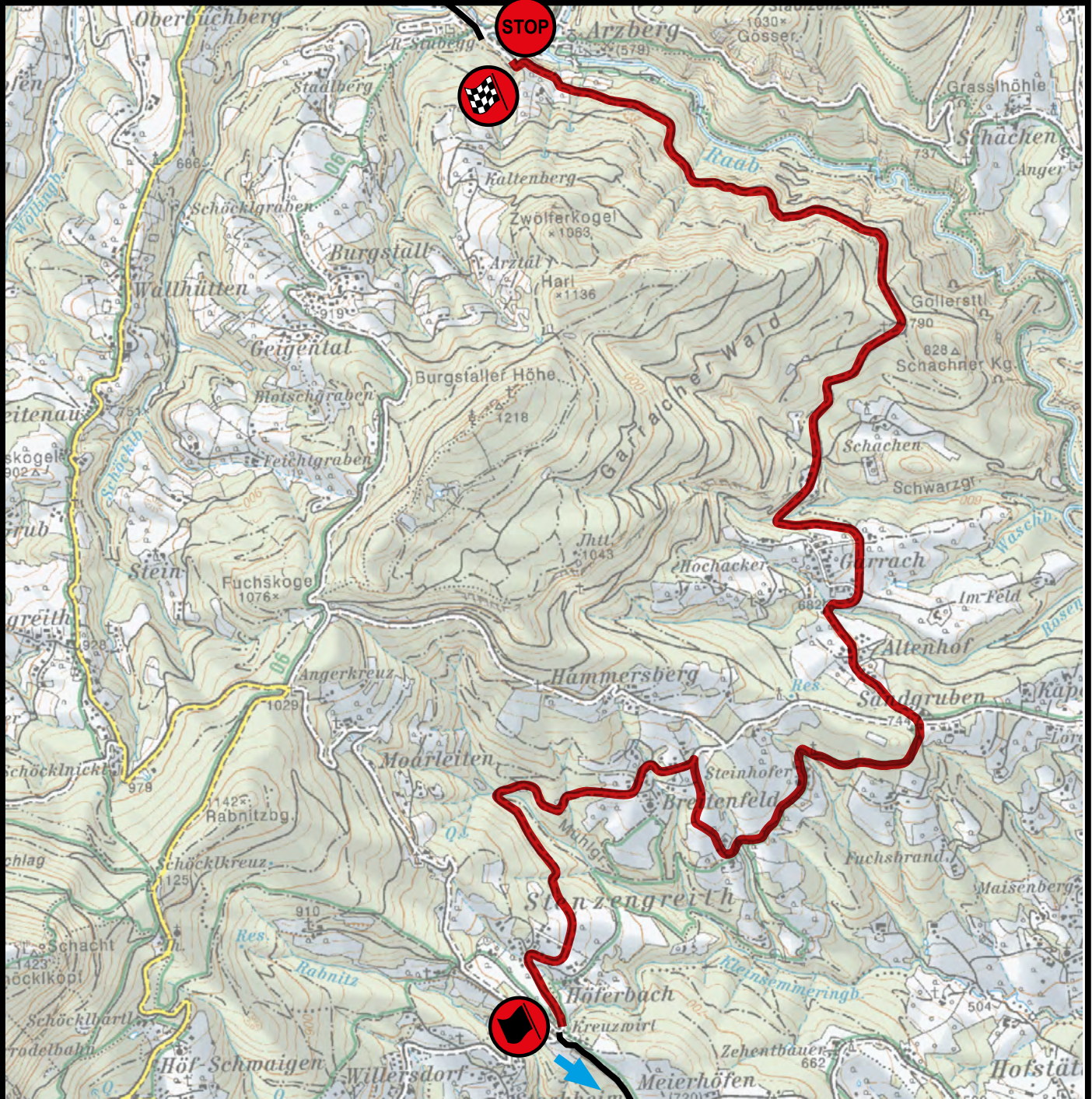

Grafik: Min., Durchschnitt, Max. Höhe: 605, 727, 790 m  
Bereichswerte: Entfernung: 12,9 km Höhendifferenz: 548 m, -708 m Maximale Steigung: 48,8%, -51,0% Durchschnittliche Steigung: 7,8%, -8,4%



11.- 13. Juli 2024

# RALLYE WEIZ



## MAP - SATURDAY

### 13.07.2024

#### Section 4&5 SS 10-13

**SS 11/13  
KOGLHOF**

**SS 10/12  
RUNDKURS NAAS**

**Weiz**  
(479)



# SP/SS 10/12 Naas

10,76 km

Saturday 13.7.2024

Route is ident with the year 2022 - 2023

11.- 13. Juli 2024

## RALLYE WEIZ

FIA  
HISTORIC  
RALLY

FIA  
EUROPEAN  
RALLY  
TROPHY

ORM  
OFFICIAL RALLY ORGANIZATION



[www.rallye-weiz.at](http://www.rallye-weiz.at)

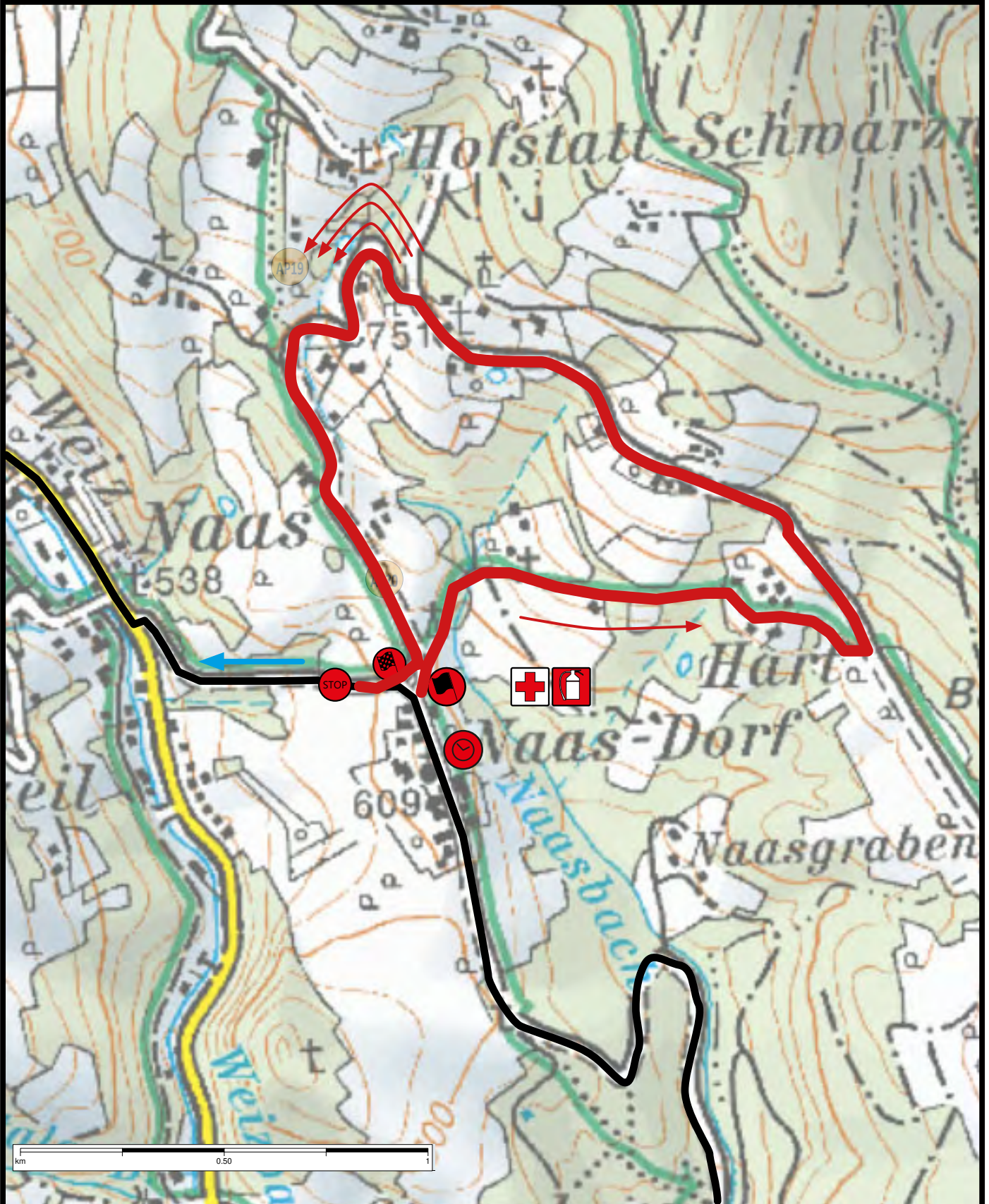

# SP/SS 11/13 Koglgof I & II

14,24 km

Samstag 13.7.2024

longer Version ident with the year 20

11.-13. Juli 2024



**RALLYE WEIZ**

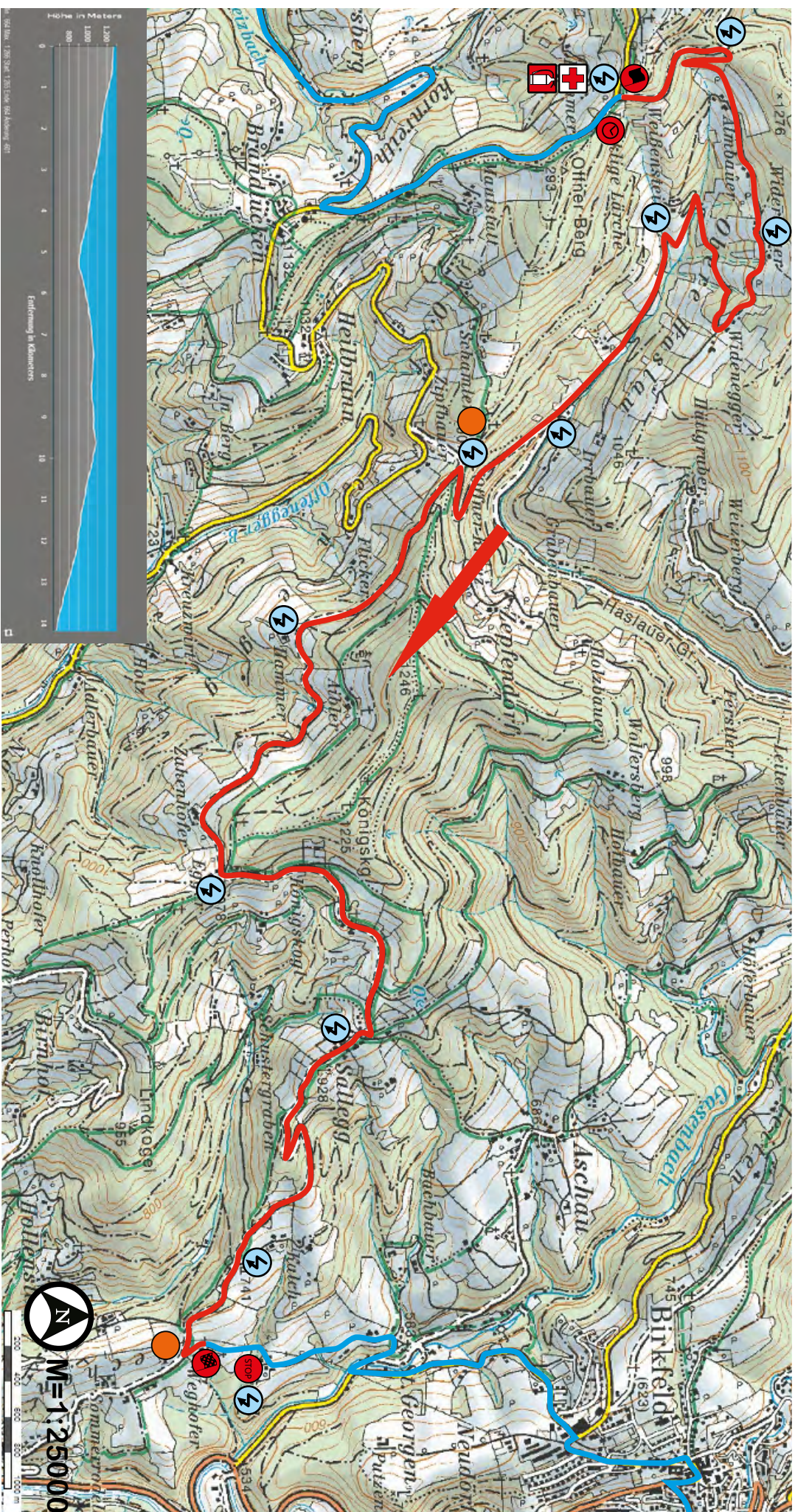

## APPENDIX 3. COMPETITORS' RELATIONS OFFICERS

### **PETER GREITER (AUT)**

TELEFON / MOBIL: +43 664 242 23 06

#### **KENNZEICHNUNG/ IDENTIFICATION:**

Rote/Magenta Weste mit der Aufschrift „CRO“

Red coloured/pink vest bearing the letters „CRO“



#### **ist anwesend / will be present:**

##### **Thursday 11. July 2024**

- in the Rally HQ, Serviceparc & Ceremonial Start

##### **Friday 12. July 2024**

- on scrutineering
- drivers briefing
- start to 1st Leg
- parc fermé on finish 1st Leg

##### **Saturday 13. July 2024**

- on the Start to 2nd Leg
- finish holding zone
- on the podium „GH Strobl“
- in finish Parc fermé
- final scrutineering

#### **further:**

- in the regroup areas and on different control zones during the rally

## APPENDIX 4. COMPETITION NUMBERS AND ADVERTISING

### **All cars must comply with the Article 2.1.9 of Appendix K.**

#### • **Competition Numbers**

**1 – door panels** 2 per car: 65x15cm, St.No. & rally name

**2 – rally plate** 43 x 21,5 cm (optional on the bonnet)

**3 – rear window / side windows** high = max. 18 cm

#### • **Optional Advertising – space reserved for Organiser's advertising**

Position under door panels: (different mutations on both sides) 2 per car: each 50 x 15 cm

Position under rear windows: (different mutations on both sides) 2 per car: each 25 x 15 cm

#### • **Driver and Co-Driver Names**

The names of the crew plus their national flags must appear on both sides of the wings at the front of the car (max size 10cm x 40cm). Any car failing to comply with this rule shall be subject to a penalty.

### **Detailed Graphics see Bulletin 1**

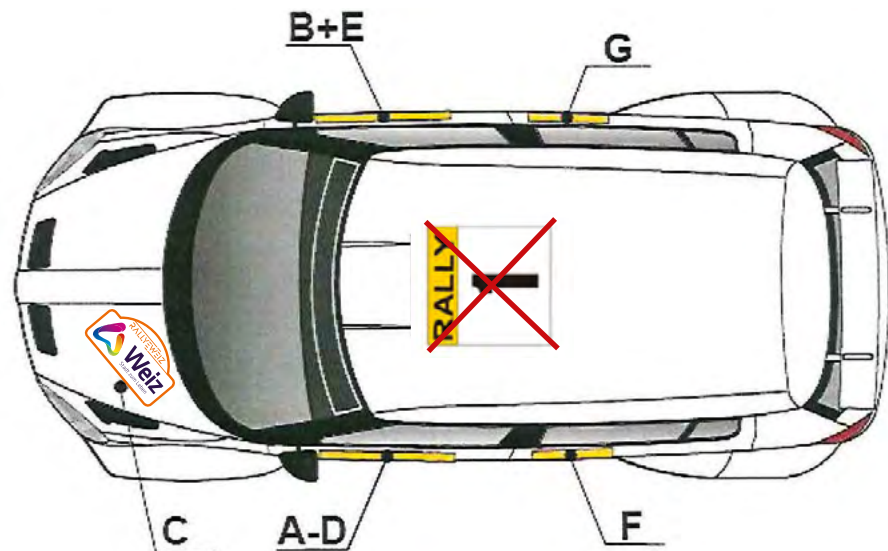
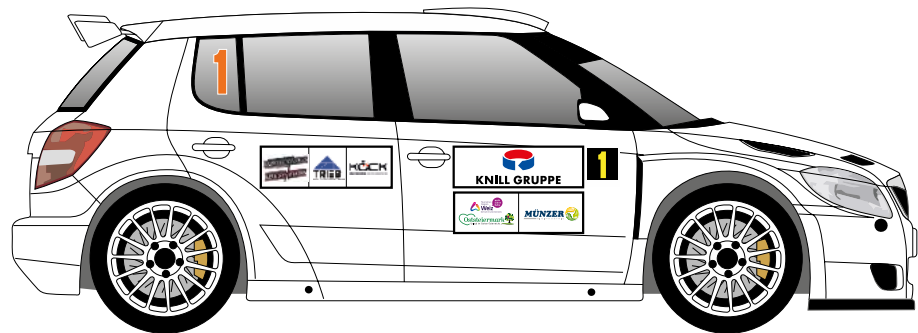
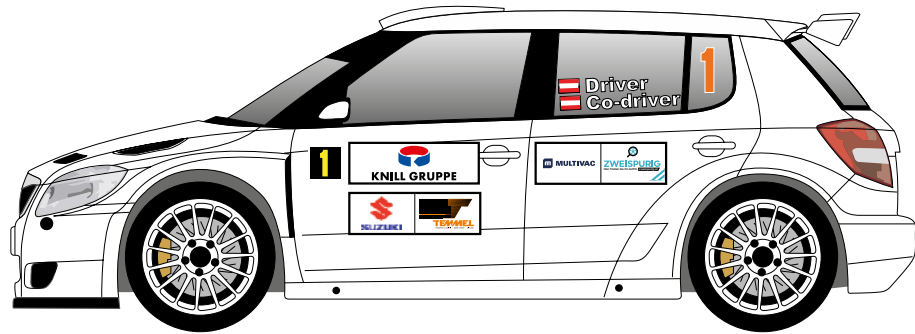
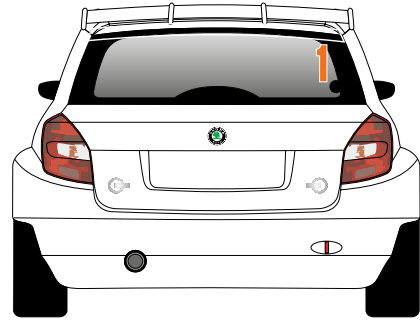

- A + B KNILL
- C WEIZ
- D SUZUKI / TEMMEL
- E TOURISMUS / MÜNZER
- F MULTIVAC / ZWEISPURIG
- G TRIEB&KREIMER / FLIESENBLITZ / AUTO KÖCK

### RELATING TO OVERALLS, HELMETS AND ANY OTHER SAFETY REQUIREMENTS

All competitors are reminded of Appendix L of the FIA International Sporting Code, in particular its Chapter III - Drivers' Equipment. Many crash helmets have expired for International rally use in 2023!

#### Helmets (Appendix L, Chapter III, Art. 1)

All crews must wear crash helmets homologated to one of the following FIA standards for 2024:

- **8859-2015 & SNELL 2015 or/SNELL 2020 (Technical List N°49) – No current expiry date.**
- **8860-2010 (or 8860-2010 & SNELL SA 2010) (Technical List N°33) - (Not valid after 2028)**
- **8860-2018 or 8860-2018-ABP (Technical List N°69) – No current expiry date.**

#### Frontal Head Restraint (FHR, Appendix L, Chapter III, Art. 3)

All crews must use FIA approved FHR systems homologated to FIA standard 8858.

Approved FHRs, anchorages and tethers are listed in Technical List N° 29.

See also helmet compatibility chart in Appendix L, Chapter III, Art. 3.3.

#### Flame-resistant clothing (Appendix L, Chapter III, Art. 2)

All drivers and co-drivers must wear overalls as well as gloves (optional for co-drivers), long underwear, a balaclava, socks and shoes homologated to the FIA 8856-2000 standard with an FIA hologram present on all items\*, (Technical List N°27) or 8856-2018 (Technical List N° 74). Please pay special attention to the prescriptions of Art. 2 concerning embroidery and printing on flame-resistant clothing (manufacturer certificates etc.) as well as concerning the correct wearing of the clothing elements! See also Regional Rally Sporting Regulations, Article 53.1.

*\*Not all fireproof socks have an FIA hologram offered by the manufacturer. Socks with FIA 8856-2000 or FIA 8856-2018 will be accepted without a hologram, subject to checking by a scrutineer. **All other items must have an FIA hologram present or they will not be accepted at scrutineering in 2024.***

#### Biometric Devices (Appendix L, Chapter III, Art. 2.1)

Drivers may choose to wear a device to collect biometric data during racing:

- If the biometric device is integrated into a protective garment homologated to FIA Standard 8856, the garment shall be homologated to FIA Standards 8856 and 8868-2018.
- If the biometric device is a stand-alone device, then the device must be homologated to FIA Standard 8868-2018 only. This device must be worn in addition to the garment homologated to FIA Standard 8856.

#### Wearing of jewellery (Appendix L, Chapter III, Art. 5)

The wearing of jewellery in the form of body piercing, metal watches (apart for co-driver use) or metal neck chains is prohibited during the competition and may therefore be checked before the start, or at any location on the rally.

#### RELATED LINKS:

FIA International Sporting Code and appendices: <https://www.fia.com/regulation/category/123>

FIA Technical Lists: <https://www.fia.com/regulation/category/761>

FIA Drivers Declaration form: <https://www.fia.com/regulation/category/117>

**Please check your compliance with these key requirements before travelling to the rally!**

### *General provisions*

All competition cars must be obligatorily equipped with the ONI® tracking system. ONI® tracking system will be rented to the competitors. Eventual destruction, non-return or damage of the unit must be paid by the competitor to the organizer in accordance with the applicable price list see Art. 9.2.1.

In case of non-returning GPS tracking system immediately after the event, the fine 200 euro will be imposed to the competitor.

### *Distribution of the ONI® tracking system*

ONI® tracking system contains following parts:

- **tracking unit with display**
- **tracking unit holder**
- **power supply cable**
- **combined antenna roof**
- **control panel containing:**

- OK button to cancel the alarm / confirm red flag
- SOS switch for calling emergency



ONI® tracking system will be installed to every rally car before each event. Detailed information will be published no later than during roadbooks issuing. After arrival to the scrutineering, device administrator will check the install of the tracking unit, antenna and control panel. Antenna and power supply cables can be purchased by the crew for personal ownership. At the end of the rally or after retirement, the tracking unit or complete tracking system must be returned to the device administrator. Usually, the devices are collected in the last service area or before finish of the rally.

### *Installation of the unit in the car*

To fit the tracking unit with display, antenna and control panel, it is necessary for the competitor to follow exactly the Installation guide, to keep the unit in good condition and to protect it against damage and fouling (especially the connectors) during the time. All rally participants will receive a rental version of the set equipped with magnetic roof antenna. Control panel with OK button and SOS switch is in one box for which the competitor has to choose a suitable place for fitting within the reach of both crew members. It is obliged to prepare everything for its installation prior to the scrutineering.

### *The unit operation during rally*

To operate the unit, the crews have to meet all instructions as mentioned in the User's guide.

#### **Operation during events on SS:**

- **Accident (crash detection)**

The unit evaluates the situation and sends info about accident to rally control. Crew cannot affect this message.

The display shows message: **Are you OK?** Confirm.

10 s after this question, the siren wails for next 15 s

If the crew pushes **OK** button, this information is sent to rally control and information about accident is not sent to the unit of following cars in the stage.

- **Stop in SS**

When the car stops in SS, it is counted as an obstacle. Unit signals to the crew by sound siren and text, that they have stopped. This signal takes 15 s.

If the crew doesn't push OK, warning message is sent to the rally control and also to other cars, which are currently in the stage arriving to the obstacle.

With pushing the OK button, the crew confirms that they are okay, on the display is shown message OK and information about obstacle is not send to the unit of next cars in the stage.

- **Request for help**

Changing the switch is confirmed by SOS message on display, also the siren sounds.

The siren sound can be cancelled by pushing OK button.

## Red flag

When the rally control hangs out the red flag, the display shows big message RED FLAG (with red background) and the siren sounds. Crew has obligation to confirm receiving the red flag by pushing the OK button and to reduce the speed according to the sporting regulations.

The siren sound can be cancelled by pushing OK button.  
The red flag on display can be cancelled only by rally control.

## Speed checking during the reconnaissance

During reconnaissance the crew is obliged to follow traffic rules of Austria. Not respecting this rule, especially exceeding the speed limits, will be monitored via ONI® tracking system. This checking doesn't exclude other checks, i.e. police controls according to their standard procedures.

## ONI® tracking system for reconnaissance

Tracking system is checking the speed in every moment during the reconnaissance. Every crew will pick up the ONI® rece tracking unit together with roadbook. Installation of the unit and using during reconnaissance is obligatory for all crews during the whole schedule of reconnaissance according to the art. 3 Reconnaissance schedule. For speed checking during the reconnaissance, NCL 21 units are used.



NCL21 unit is started during roadbook issuing before starting of reconnaissance. For whole reconnaissance the unit is working on its own battery. It is not necessary to plug the unit to any power supply. It is possible to place the unit on metal surfaces - magnets are implemented in the unit. Not using the unit in a rally car during reconnaissance will be fined. Every attempt to falsify, manipulate or infringe the unit for reconnaissance or any device, which will make impossible to collect data because of external interference will be reported to the stewards who can penalize the crew up to refusing the start. Decision regarding seriousness of the offence and its repeating is in Clerk of the Course authority. For exceeding the speed limit, sanctions can be given according to supplementary regulations or championship regulations.

## REFERENCE USER GUIDE OF THE ONI GPS SYSTEM

**Main unit of the ONI system**

- Display (i.e. liaison mode displayed)
- Language set (long press)
- Day / night brightness (long press)
- SS 02 START
- SS Start, number of the SS is also displayed.
- SS 02 0,5 km
- After started, the driven distance in the SS is shown.

**Remote control panel**

- Cancel / accept button (OK)
- SOS - switch - Medical help (T-SOS)

Stopped, NOT blocking	Stopped, BLOCKING	Accident	SOS - Medical help	Red flag
<p><b>Situation:</b></p> <ul style="list-style-type: none"> <li>Puncture change on SS</li> <li>Technical issue</li> <li>Retired</li> <li>Car slid into ditch...</li> </ul> <p><b>What to do?</b></p> <ul style="list-style-type: none"> <li>Press the OK when the car has stopped</li> <li>If retired inform the Rally control</li> <li>If parked on the side of the road, please use the warning triangle!</li> <li>Use the paper green OK sign if the car is damaged and visible from the SS track.</li> </ul> <p><b>Other crews see on the GPS:</b></p> <ul style="list-style-type: none"> <li>No information is displayed on the GPS unit to the approaching crews.</li> </ul>	<p><b>Situation:</b></p> <ul style="list-style-type: none"> <li>Completely blocked road</li> <li>Car stopped in a very dangerous place (tech. issue, repair...)</li> </ul> <p><b>What to do?</b></p> <ul style="list-style-type: none"> <li>Do NOT press OK after stopping</li> <li>Try to push the car away</li> <li>Call Rally control</li> <li>Unit is displaying, after 30 sec:</li> </ul> <p>ARE YOU OK?</p> <ul style="list-style-type: none"> <li>Keep displayed. OK button should be pressed once the track is clear or you continue driving.</li> </ul> <p><b>Other crews see:</b></p> <ul style="list-style-type: none"> <li>The Unit in the approaching car is displaying, with one beep:</li> </ul> <p>1267 m</p>	<p><b>Situation:</b></p> <ul style="list-style-type: none"> <li>Accident automatically recorded by ONI unit:</li> </ul> <p>CRASH ARE YOU OK? CONFIRM</p> <p><b>What to do?</b></p> <ul style="list-style-type: none"> <li>Medical help needed: Use T-SOS switch, see next point</li> <li>Crew and SS track OK: Press OK</li> <li>Track blocked: Do NOT press OK</li> </ul> <p><b>Other crews see:</b></p> <ul style="list-style-type: none"> <li>The Unit in the approaching car is displaying, with constant beep</li> </ul> <p>ACCIDENT 1267 m</p> <ul style="list-style-type: none"> <li>Should the crashed crew press the OK, warning disappears.</li> </ul>	<p><b>Situation:</b></p> <ul style="list-style-type: none"> <li>Accident - ambulance needed</li> <li>Calling help for other crew after arriving to crash scene</li> <li>Calling help for spectators...</li> </ul> <p><b>What to do?</b></p> <ul style="list-style-type: none"> <li>Use the T-SOS Switch</li> <li>Call Rally control if possible</li> <li>Unit will display:</li> </ul> <p>THE UNIT ANNOUNCED SOS</p> <p><b>Other crews see:</b></p> <ul style="list-style-type: none"> <li>The Unit in the approaching car is displaying, with constant beep</li> </ul> <p>SOS 1267 m</p>	<p><b>Situation:</b></p> <ul style="list-style-type: none"> <li>Red flag issued by the Rally controls. Unit displays, together with continuous beeping signal:</li> </ul> <p>RED FLAG</p> <p><b>What to do?</b></p> <ul style="list-style-type: none"> <li>You are obliged to accept the flag by pressing OK, that mutes the sound alarm as well.</li> <li>Driver is obliged to decrease the speed immediately and safely continue in direction to the SS finish and/or following Marshals instructions should the road be blocked.</li> <li>Notional time is given</li> </ul>

**Manuals and more informations on:**  
[www.onisystem.cz/rally](http://www.onisystem.cz/rally)

**Download**  
**Unit Installation Video**  
**!! 200 MB**

**Download**  
**ONI SYSTEM**  
**GPS USER GUIDE**

# IMPORTANT! Following preparation MUST BE DONE BEFORE THE CAR ENTERS TO SCRUTINEERING! If not done, car will be rejected to enter the scrutineering!

Example of Turbo sealing wire install (applies to J2 GrpN and GrpA turbo cars, also spare turbo). Every main part (restrictor, housing and exhaust housing) must have two attachment points where the wire is installed (wire through two bolts OR bolt and housing OR two housing). Wire must be single piece and wrapped between every attachment point. See Appendix K Appendix XI item 2.1.3

## 5/ SEALING OF THE TURBOCOMPRESSOR

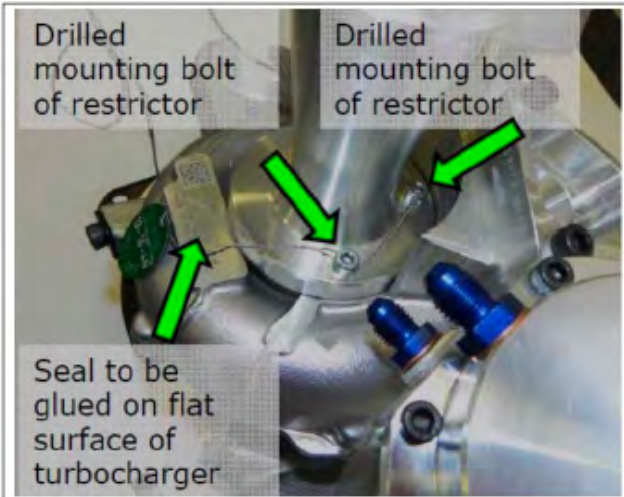

Example how to route the wire through two restrictor mounting bolts. Seal tag number shall be visible from upwards

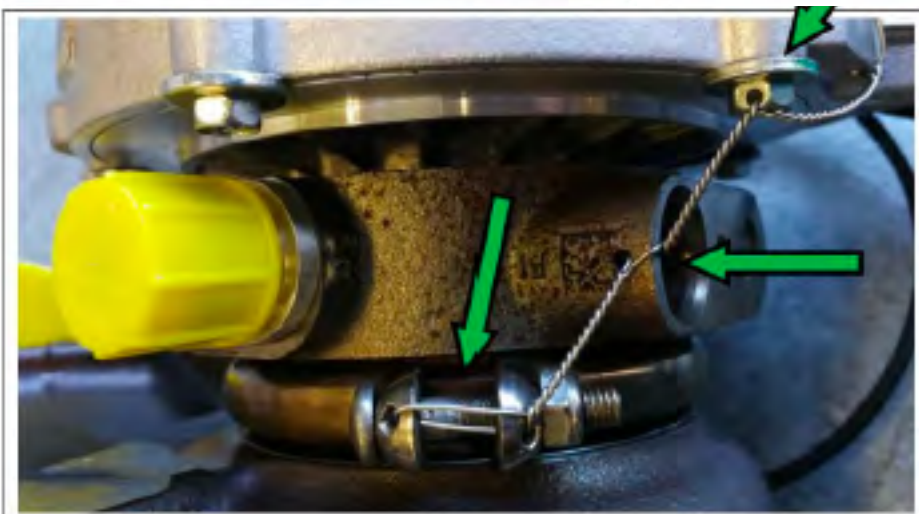
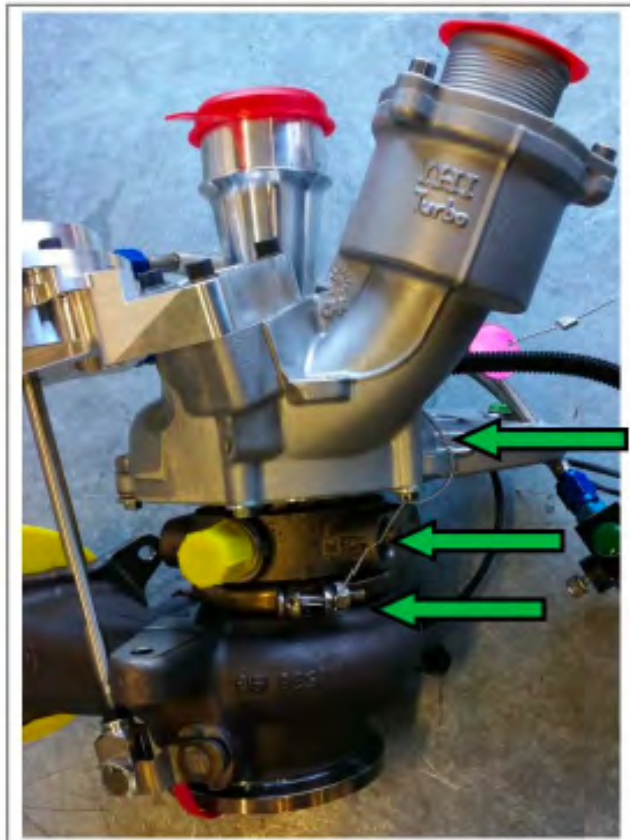

Example how to route wire through housing and exhaust (base part + mounting bolt)

# TECH-INFO

11.- 13. Juli 2024

## RALLYE WEIZ



Example how to route the wire for exhaust side (housing + mounting clamp)

Note, that after last wire mounting place there shall be free wire ends (min 150mm long) to make it possible to wrap first 20mm and then add seal+tag+seal, having 20mm between each.